

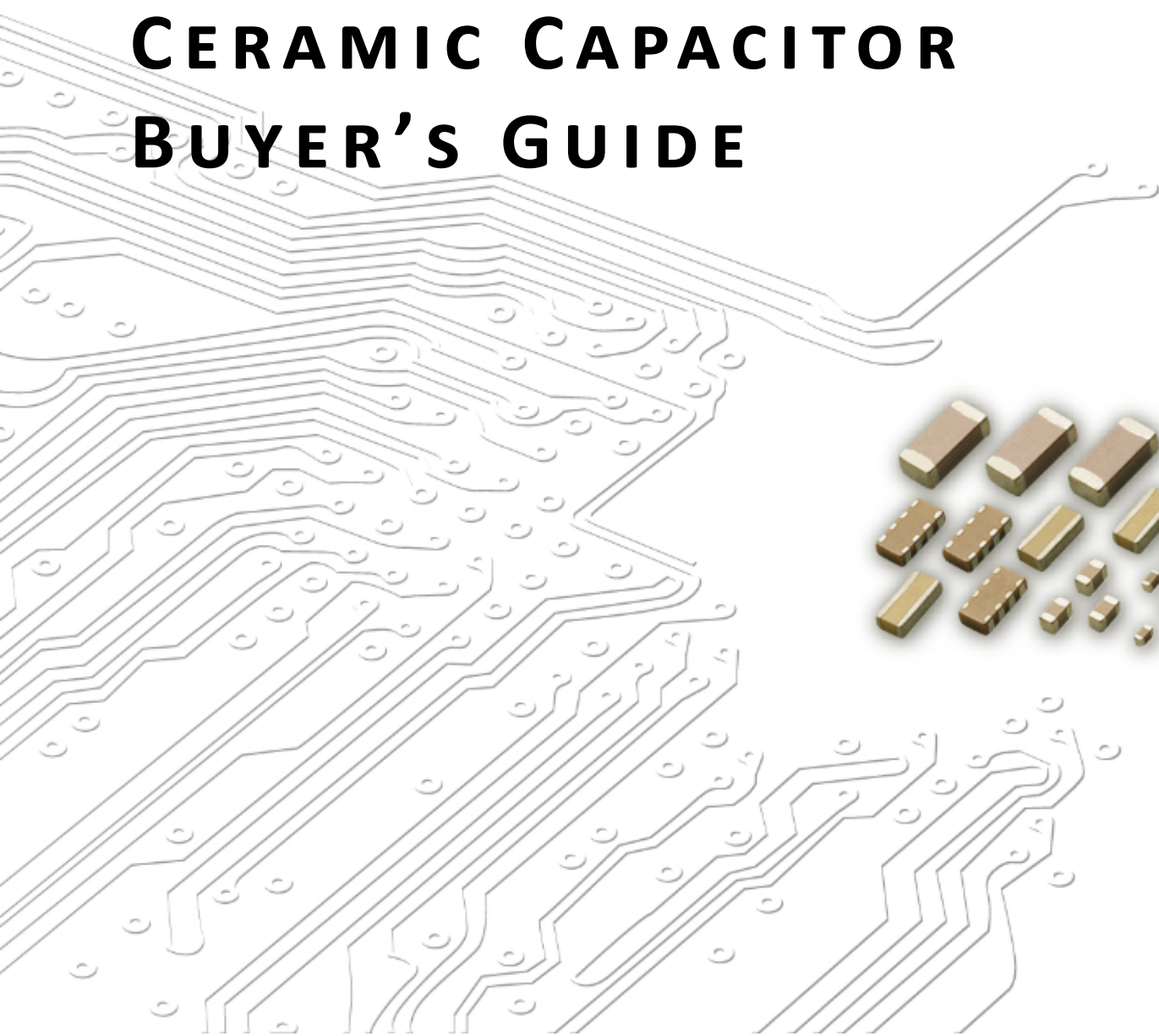

CERAMIC CAPACITOR BUYER'S GUIDE



S-P International offers a complete line of ceramic capacitor products to meet all customer requirements, in both SMD and through-hole styles under our Sanyo-CAP brand name. For over 45 years, Canadian and world-wide manufacturers have come to depend on S-P International's Sanyo-CAP brand of ceramic capacitors. Whatever your requirement may be, SMD, MLCC, or basic disc ceramic, from 6.3 volts to over 6K volts, S-P International has the right capacitor for your requirements.

S-P International draws on the expertise of Asia's major capacitor manufacturers to bring you the right products at the right prices. Please note that not all products are carried in stock and some are subject to minimum order quantities. We have listed the most popular items in both through-hole and SMD packaging. Contact your local S-P International office or distributor with your requirements for complete specifications and pricing.





S-P International - Burnaby B.C.
Corporate Head Office and Warehouse



S-P International - Markham, Ontario
Sales Office - Eastern Region



 	<p>S-P International's Sanyo-CAP ceramic capacitors are Pb Free, and are fully RoHS & REACH Compliant as well as meeting all of the Conflict Minerals Report requirements. Leads are matte tin plated. For further information on S-P International's lead free products, please contact your local distributor or S-P International directly.</p>	
--	--	---



Sanyo-CAP is a trademark of S-P International

NOTICE:

Data given in the publication is subject to product improvement change without prior notification. Certain products listed in this publication are subject to factory minimum production requirements.

Catalogue created by Arthur Baier and edited by Heidi Wassersleben for S-P International.

Contents

Capacitor Series	Capacitor Type	Page
SMD Series	SMD General Purpose	4
AU Series	SMD Automotive Grade AE-Q200	10
S2 Series	SMD X1 / Y2 Safety Certified	12
S3 Series	SMD X2 / Y3 Safety Certified	13
SG Series	SMD Soft Termination	14
SH Series	SMD Soft Termination	16
TC Series	Class I - Temperature Compensation	22
HC Series	Class II - Hi-K	24
HC Series	X7R	26
HC Series	Class III - Semi-Conductive	27
UC / UA Series	Multilayer (MLCC)	28
	Taping Specification	30
	Lead Styles	32
	Typical Characteristic Curves	33
	General Notes	36
	Reflow Solder Temperature Chart	37

SMD General Purpose Ceramic Capacitors



GENERAL SPECIFICATION

	NPO	X7R	X5R	Y5V*
Capacitance Range	0.1pF ~ 33nF	100pF ~ 47μF	0.047μF ~ 330μF	0.01μF ~ 4.7μF
Capacitance Tolerance	B, C, D, F, G, J, K	J, K, M		Z
Temperature Characteristic	±30ppm	±15 %		+30/-80 %
Available Sizes	01005 ~ 2220		01005 ~ 1812	0402 ~ 0805
Operating Temperature	-55°C ~ +125°C		-55°C ~ +85°C	-25°C ~ +85°C
Rated Voltage (WVDC)	6.3V ~ 5KV			10V ~ 50V
Termination	Ni/Sn (Lead-free Termination)			

* Y5V - NOT FOR NEW DESIGN. Available only while stock is available.

CONSTRUCTION

1	Ceramic Dielectric
2	Inner Electrodes
3	Inner Layer
4	Middle Layer - Ni
5	Outer Layer - Sn

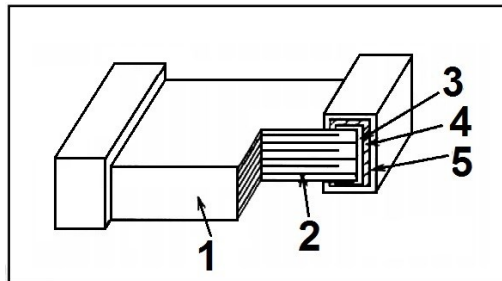

01005

	NPO	Case	X7R	Case	X5R	Case
6.3V	-----	-	120 ~ 1,000	V	120 ~ 0.1μF	V
10V	0.1 ~ 100	V	120 ~ 1,000	V	120 ~ 10,000	V
16V	0.1 ~ 100	V	120 ~ 1,000	V	120 ~ 10,000	V
25V	0.1 ~ 100	V	-----	-	-----	-
50V	0.1 ~ 100	V	-----	-	-----	-

0201

	NPO	Case	X7R	Case	X5R	Case
6.3V	-----	-	-----	-	15nF ~ 0.68nF	C
					100nF ~ 470nF	D
					1.0μF~2.2μF	T
10V	-----	-	100 ~ 33,000	C	15nF ~ 0.68nF	C
					100nF ~ 470nF	D
					1.0μF ~ 2.2μF	T
16V	-----	-	100 ~ 33,000	C	15nF ~ 0.68nF	C
					100nF	D
25V	0.1 ~ 680	C	100 ~ 10,000	C	15nF ~ 68nF	C
					100nF	D
50V	0.1 ~ 680	C	100 ~ 4,700	C	4.7nF ~ 10nF	C

0402

	NPO	Case	X7R	Case	X5R	Case
6.3V	-----	-	120 ~ 0.10μF	E	0.1μF	E
			0.22μF~0.68μF	F	220nF~680nF	F
			1μF	N	1μF~10μF	N
10V	-----	-	120 ~ 0.10μF	E	0.1μF	E
			0.22μF~0.68μF	F	220nF~680nF	F
			1μF	N	1μF~10μF	N
16V	-----	-	120 ~ 100nF	E	0.1μF	E
			220nF ~ 470nF	F	220nF~680nF	F
			-----	-	1μF ~ 4.7μF	N
25V	0.1 ~ 1,200	E	120 ~ 0.1μF	E	100nF	E
			0.22μF	F	220nF~680nF	F
50V	0.1 ~ 1,000	E	120 ~ 0.10μF	E	47nF ~ 100nF	E
100V	33 ~ 270	E	1000 ~ 10nF	E	-----	-

All values in "pF" unless noted oth-

0603

	NPO	Case	X7R	Case	X5R	Case
6.3V	-----	-	100 ~ 680nF	H	470nF ~ 680nF	H
			1μF ~ 4.7μF	B	1μF ~ 47μF	B
10V	-----	-	100 ~ 680nF	H	470nF ~ 680nF	H
			1μF ~ 4.7μF	B	1μF ~ 22μF	B
16V	-----	-	100 ~ 0.68μF	H	470nF ~ 680nF	H
			1μF ~ 2.2μF	B	1μF ~ 10μF	B
25V	0.1 ~ 10nF	H	100 ~ 0.68μF	H	470nF ~ 680nF	H
			1μF ~ 2.2μF	B	1μF ~ 10μF	B
50V	0.1 ~ 10nF	H	100 ~ 0.68μF	H	470nF ~ 680nF	H
			1.0μF	B	1.0μF	B
100V	22 ~ 1,000	H	100 ~ 100nF	H	-----	-
200V	100 ~ 470	H	330 ~ 10nF	H	-----	-
250V	180 ~ 330	H	3,300 ~ 10nF	H	-----	-

0805

	NPO	Case	X7R	Case	X5R	Case
6.3V	-----	-	100 ~ 330nF	B	1.0μF ~ 47μF	J
			470nF ~ 10μF	J		
10V	-----	-	100 ~ 330nF	B	1.0μF ~ 47μF	J
			470nF ~ 10μF	J		
16V	-----	-	100 ~ 330nF	B	1.0μF ~ 22μF	J
			470nF ~ 10μF	J		
25V	0.1 ~ 10nF	B	100 ~ 330nF	B	1.0μF ~ 22μF	J
	12nF ~ 22nF	J	0.47μF ~ 4.7μF	J		
50V	0.1 ~ 10nF	B	100 ~ 330nF	B	1.0μF ~ 10μF	J
	12nF ~ 22nF	J	0.47μF ~ 2.2μF	J		
100V	10 ~ 3,300	B	220 ~ 22nF	B	-----	-
			33nF ~ 4.7μF	J		
200V	100 ~ 1,000	B	10nF	B	-----	-
			15nF ~ 33nF	J		
250V	100 ~ 1,000	B	100 ~ 33nF	J	-----	-
500V	12 ~ 150	B	100 ~ 100nF	J	-----	-
	180 ~ 470	J				
630V	-----	-	1,000 ~ 5,600	J	-----	-
1KV	6.8 ~ 8.2	B	1,000 ~ 2,200	J	-----	-
	10 ~ 100	J				
2KV	-----	-	1,000	J	-----	-

1206

	NPO	Case	X7R	Case	X5R	Case
6.3V	-----	-	330 ~ 220nF	B	1.0μF ~ 100μF	L
			0.33μF ~ 680nF	J		
			1.0μF ~ 22μF	L		
10V	-----	-	330 ~ 220nF	B	1.0μF ~ 47μF	L
			0.33μF ~ 0.68μF	J		
			1.0μF ~ 22μF	L		
16V	-----	-	330 ~ 220nF	B	1.0μF ~ 47μF	L
			0.33μF ~ 680nF	J		
			1.0μF ~ 10μF	L		
25V	0.1 ~ 6,800	B	330 ~ 220nF	B	1.0μF ~ 22μF	L
	10nF	J	0.33μF ~ 680nF	J		
	12nF ~ 100nF	L	1.0μF ~ 10μF	L		
50V	0.1 ~ 6,800	B	330 ~ 220nF	B	1.0μF ~ 10μF	L
	10nF	J	330nF ~ 680nF	J		
	12nF ~ 100nF	L	1.0μF ~ 10μF	L		
100V	330 ~ 2,200	B	100 ~ 56nF	B	-----	-
			68nF ~ 330nF	J		
			470nF ~ 1.0μF	L		
200V	27 ~ 680	B	100 ~ 22nF	B	-----	-
	1,000	J	33nF ~ 100nF	J		
	-----	-	0.22μF	L		
250V	68 ~ 2,200	B	330 ~ 22nF	B	-----	-
			33nF ~ 68nF	J		
			100nF ~ 220nF	L		
500V	0.5 ~ 5.6	B	150 ~ 2,200	B	-----	-
	6.8 ~ 680	J	2,700 ~ 47,000	J		
	1,000 ~ 1,500	L	56nF ~ 100nF	L		
630V	0.5 ~ 5.6	B	100 ~ 22nF	J	-----	-
	6.8 ~ 680	J	33nF ~ 47nF	L		
	1,000 ~ 1,500	L	-----	-		
1KV	0.5 ~ 5.6	B	100 ~ 5,600	J	-----	-
	6.8 ~ 680	J	6,800	L		
	1,000 ~ 1,000	L	-----	-		
2KV	2 ~ 56	J	100 ~ 5,600	J	-----	-
	68 ~ 220	L	6,800	L		
3.5KV	39	L	1,000	J	-----	-

All vales in "pF" unless noted other-

1210

	NPO	Case	X7R	Case	X5R	Case
6.3V	-----	-	330 ~ 100nF	J	4.7μF ~ 100μF	O
			220nF	K		
			330nF ~ 4.7μF	L		
			6.8μF ~ 47μF	O		
10V	-----	-	330 ~ 100nF	J	4.7μF ~ 47μF	O
			220nF	K		
			330nF ~ 4.7μF	L		
			6.8μF ~ 47μF	O		
16V	-----	-	330 ~ 100nF	J	4.7μF ~ 47μF	O
			220nF	K		
25V	10 ~ 10nF	J	330 ~ 100nF	J	4.7μF	P
			220nF	K	6.8μF ~ 22μF	O
			330nF ~ 4.7μF	L	-----	-
50V	10 ~ 10nF	J	330 ~ 100nF	J	4.7μF	P
			220nF	K	6.8μF ~ 10μF	O
			330nF ~ 4.7μF	L	-----	-
100V	100 ~ 6,800	J	4,700 ~ 0.1μF	J	-----	-
			0.22μF ~ 1.0μF	L		
			2.2μF ~ 4.7μF	O		
			47nF	J		
200V	100	J	47nF	J	-----	-
			1,000 ~ 0.10μF	L	-----	-
250V	-----	-	0.22μF ~ 0.33μF	O		
			500V	10 ~ 680	J	3,300 ~ 22nF
1,000 ~ 1,800	L					
2,200	P					
2,700	S					
630V	-----	-	680 ~ 33nF	J	-----	-
			47nF	S		
			56nF ~ 0.1μF	L		
1KV	68 ~ 100	J	220	J	-----	-
	120 ~ 680	L				
	1,000 ~ 1,800	S				
	2,200 ~ 6,800	O				
2KV	39	J	220	J	-----	-
	47 ~ 180	L				
	220 ~ 270	P				
	330	S				

1808

	NPO	Case	X7R	Case	X5R	Case
6.3V	-----	-	330 ~ 4.7μF	L	330 ~ 6.8μF	L
10V	-----	-	330 ~ 4.7μF	L	330 ~ 6.8μF	L
16V	-----	-	330 ~ 4.7μF	L	330 ~ 6.8μF	L
25V	-----	-	330 ~ 4.7μF	L	330 ~ 4.7μF	L
50V	10 ~ 0.1μF	L	330 ~ 1.0μF	L	330 ~ 1.0μF	L
100V	2.0 ~ 4,700	L	470 ~ 0.1μF	L	-----	-
200V	2.0 ~ 3,900	L	1,000 ~ 0.47μF	L	-----	-
250V	2.0 ~ 3,900	L	220 ~ 0.22μF	L	-----	-
500V	330 ~ 1,000	L	47nF	L	-----	-
	1,500 ~ 4,700	P				
630V	2.0 ~ 2,700	L	-----	-	-----	-
1KV	33 ~ 1,000	L	220 ~ 22nF	L	-----	-
2KV	100 ~ 470	L	100 ~ 10nF	L	-----	-
	560 ~ 1,800	S				
3KV	1.0 ~ 220	L	100 ~ 4,700	L	-----	-
	270 ~ 330	S				
4KV	-----	-	1,000	L	-----	-
5KV	3.0 ~ 68	L	150 ~ 1,000	L	-----	-
	100	S				

1812

	NPO	Case	X7R	Case	X5R	Case
6.3V	-----	-	330 ~ 1.0μF	M	330 ~ 1.0μF	M
			2.2μF ~ 6.8μF	R	2.2μF ~ 6.8μF	R
10V	-----	-	330 ~ 1.0μF	M	330 ~ 1.0μF	M
			2.2μF ~ 6.8μF	R	2.2μF ~ 6.8μF	R
16V	-----	-	330 ~ 1.0μF	M	330 ~ 1.0μF	M
			2.2μF ~ 6.8μF	R	2.2μF ~ 6.8μF	R
25V	10 ~ 33nF	L	330 ~ 1.0μF	M	330 ~ 1.0μF	M
			2.2μF ~ 6.8μF	R	2.2μF ~ 6.8μF	R
50V	10 ~ 33nF	L	330 ~ 1.0μF	M	330 ~ 1.0μF	M
			2.2μF ~ 6.8μF	R	2.2μF ~ 6.8μF	R
100V	56 ~ 4,700	J	10nF ~ 470nF	J	-----	-
	22nF ~ 33nF	O	680nF ~ 1.0μF	S		
	-----	-	2.2μF	O		
200V	3,900 ~ 4,700	J	1,000 ~ 220nF	L	-----	-
			330nF ~ 1.0μF	S		
250V	-----	-	1,000 ~ 100nF	L	-----	-
			220nF ~ 330nF	S		
			470nF	O		
			680nF ~ 1.0μF	S		
500V	22 ~ 1,000	J	1.8nF ~ 100nF	L	-----	-
	1,500 ~ 4,700	L	220nF	S		
630V	1,000 ~ 4,700	L	22nF ~ 68nF	L	-----	-
			100nF	S		
1KV	3.3 ~ 1,500	L	270 ~ 47,000	L	-----	-
	1,800 ~ 2,200	O	56nF	S		
2KV	22 ~ 560	L	270 ~ 12,000	L	-----	-
	680 ~ 1,000	S	15nF ~ 18nF	S		
3KV	3.3 ~ 270	L	150 ~ 4,700	L	-----	-
	330 ~ 560	S	5.6nF ~ 6.8nF	S		
	-----	-	10nF	O		
4KV	-----	-	150 ~ 2,200	L	-----	-
			2,700 ~ 3,300	P		
5KV	1.0 ~ 22	L	2,200	S	-----	-

2220

	NPO	Case	X7R	Case	X5R	Case
6.3V	-----	-	-----	-	4.7μF ~ 100μF	L
10V	-----	-	-----	-	4.7μF ~ 47μF	L
16V	-----	-	-----	-	4.7μF ~ 22μF	L
25V	-----	-	-----	-	4.7μF ~ 10μF	L
50V	-----	-	-----	-	-----	-
100V	-----	-	470nF ~ 1μF	L	-----	-
			2.2μF	P		
			3.3μF ~ 10μF	S		
200V	-----	-	47nF ~ 680nF	L	-----	-
250V	-----	-	2,200 ~ 1μF	L	-----	-
			2.2μF	S		
500V	-----	-	330 F ~ 470nF	L	-----	-
630V	-----	-	150nF ~ 470nF	L	-----	-
1KV	-----	-	4,700 F ~ 47nF	L	-----	-
			56nF ~ 220nF	S		
2KV	-----	-	1,000 ~ 47nF	L	-----	-
2.5KV	-----	-	10nF	L	-----	-
3KV	-----	-	1,000 ~ 10nF	L	-----	-
4KV	-----	-	1,000 ~ 8,200	L	-----	-
			1,000 ~ 1,800	L		
5KV	-----	-	2,200 ~ 4,700	S	-----	-
			-----	-		

Contact S-P International for availability of 2225 size parts.

All vales in "pF" unless noted other-

DIMENSIONS & PACKAGING - T&R - 7"

Size	L	W	T / Symbol	M _B	Qty T&R - 7"
01005	0.40 ±0.02	0.20 ±0.02	0.20 ±0.02 V	0.10 ±0.03	20,000
0201	0.60 ±0.03	0.30 ±0.03	0.30 ±0.03 C	0.15 ±0.05	15,000
	0.60 ±0.05	0.30 ±0.05	0.30 ±0.05 D		
	0.60 ±0.10	0.30 ±0.10	0.30 ±0.10 T		
0402	1.00 ±0.05	0.50 ±0.05	0.50 ±0.05 E	0.25 ±0.05	10,000
	1.00 ±0.15	0.50 ±0.15	0.50 ±0.15 F		
	1.00 ±0.20	0.50 ±0.20	0.50 ±0.20 N		
0603	1.60 ±0.10	0.80 ±0.10	0.80 ±0.10 H	0.35 ±0.20	4,000
	1.60 ±0.20	0.80 ±0.20	0.80 ±0.20 B		
0805	2.00 ±0.20	1.25 ±0.20	0.80 ±0.20 B	0.50 ±0.20	4,000
			1.25 ±0.20 J		2,000
1206	3.20 ±0.30	1.60 ±0.30	0.80 ±0.20 B	0.60 ±0.30	4,000
			1.00 ±0.20 I		3,000
			1.25 ±0.20 J		2,000
			1.60 ±0.20 M		
			1.60 ±0.30 L		
1210	3.20 ±0.30	2.50 ±0.30	1.25 ±0.20 J	0.60 ±0.30	2,000
			1.40 ±0.20 K		
			1.60 ±0.30 L		
			1.80 ±0.30 P		1,000
			2.00 ±0.20 R		
			2.00 ±0.30 S		
			2.5 ±0.30 O		

Size	L	W	T / Symbol	M _B	Qty T&R - 7"
1808	4.50 ±0.40	2.00 ±0.20	1.60 ±0.30 L	0.60 ±0.30	2,000
			1.80 ±0.30 P		
			2.00 ±0.30 S		
1812	4.50 ±0.40	3.20 ±0.30	1.25 ±0.20 J	0.60 ±0.30	1,000
			1.60 ±0.20 M		
			1.60 ±0.30 L		500
			2.00 ±0.20 R		
			2.00 ±0.30 S		
			2.50 ±0.30 O		
2220	5.70 ±0.40	5.00 ±0.40	1.60 ±0.30 L	0.60 ±0.30	500
			1.80 ±0.30 P		
			2.00 ±0.30 S		
			2.50 ±0.30 O		

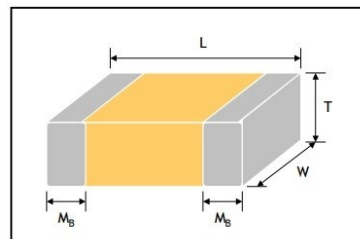

PART NUMBER

U 1206 C 331 J C T

Voltage	Size Code	Material	Value	Tolerance	Termination	Options
L = 4.0V	1005	C = NPO	1R5 = 1.5pF	C = ±.25pF	C or N	T = T&R
K = 6.3V	0201	R = X7R	100 = 10pF	D = ±.5pF	Contact SPI	Blank = Bulk
N = 10V	0402	X = X5R	101 = 100pF	F = 1%		
B = 16V	0603	F = Y5V*	102 = 1,000pF	G = 2%		
T = 25V	0805	E = Z5U**	103 = 0.01µF	J = 5%		
U = 50V	1206		104 = 0.1µF	K = 10%		
A = 100V	1210			M = 20%		
D = 200V	1808			Z = -20+80%		
H = 250V	1812					
C = 500V						
D = 630V						
M = 1000V						
M2 = 2000V						
M3 = 3000V						
M4 = 4000V						
M5 = 5000V						

* Y5V - NOT FOR NEW DESIGN. Available only while stock is available.
 ** Z5U - NOT FOR NEW DESIGN. Available only while stock is available.

LEAD FREE
 All SMD Series are RoHS &
 REACH Compliant, Matte Tin

ENVIRONMENTAL CHARACTERISTICS

ITEM	REQUIREMENT							TEST METHOD			
Capacitance	Should be within the specified tolerance							NPO: (Class I) Cap ≤ 1,000pF: 1.0±0.2Vrms, 1MHz ±10% Cap >1,000pF: 1.0±0.2Vrms, 1KHz ±10% X7R, X5R: (Class II) Cap ≤ 10μF: 1.0±0.2Vrms, 1KHz ±10% Cap >10μF: 0.5±0.1Vrms, 120KHz ±24Hz			
(DF, Tan δ) Dissipation Factor (01005 Size)	NPO						≤0.25%	Test Temperature: 25°C ±3°C Test Frequency: 1.0 ±0.2Vrms, 1MHz ±10%			
	X7R, X5R						≤10%	Test Temperature: 25°C ±3°C Test Frequency: 1.0 ±0.2Vrms, 1KHz ±10%			
(DF, Tan δ) Dissipation Factor	NPO						Cap ≥ 30pF, DF ≤ 0.1% Cap < 30pF, DF ≤ 1/(400+20C)				
	X7R, X5R	Voltage	DF	0201	0402	0603	0805	≥1206	NPO (Class I) Caps ≤ 1nF: 1.0 ±0.2Vrms, 1MHz ±10% Cap > 1nF: 1.0 ±0.2Vrms, 1KHz ±10% X7R, X5R (Class II) Caps ≤ 10μF: 1.0 ±0.2Vrms, 1KHz ±10% Cap > 10μF: 0.5 ±0.2Vrms, 120Hz ±10%		
				≤250	-	≤10nF	≤100nF	≤330nF		≤680nF	
				≤350	≤3.3nF	≤47nF	≤470nF	≤1μF		≤2.2μF	
				50V	≤500	≤10nF	≤0.1μF	-		-	-
				≤750	-	-	-	≤2.2μF		≤4.7μF	
				≤1,000	-	-	≤2.2μF	≤10μF		≤10μF	
				25V	≤250	-	≤10nF	≤150nF		-	≤680nF
					≤350	≤3.3nF	≤47nF	≤470nF		≤1μF	-
					≤500	≤10nF	≤0.22μF	-		-	-
					≤750	≤10nF	-	-		≤2.2μF	≤10μF
					≤1,000	≤100nF	≤2.2μF	≤10μF		≤22μF	≤22μF
				16V	≤250	-	≤10nF	≤100nF		-	≤680nF
					≤350	≤3.3nF	≤47nF	≤470nF		≤1μF	-
					≤500	≤15nF	≤220nF	-		-	-
					≤750	≤10nF	≤47nF	-		≤4.7μF	≤10μF
					≤1,000	≤100nF	≤4.7μF	≤10μF		≤22μF	≤47μF
				10V	≤250	-	≤10nF	≤150nF		-	≤680nF
					≤350	≤3.3nF	≤47nF	≤470nF		≤1μF	-
					≤500	≤15nF	≤220nF	-		-	-
					≤750	≤100nF	-	≤2.2μF		-	≤10μF
					≤1,000	≤2.2μF	≤10μF	≤22μF		≤47μF	≤47μF
				≤6.3V	≤250	-	≤10nF	≤100nF		-	≤680nF
					≤350	≤3.3nF	≤47nF	≤470nF		≤1μF	-
					≤500	≤15nF	≤220nF	-		-	-
					≤750	≤47nF	-	-		2.2μF	≤10μF
					≤1,000	≤2.2μF	≤10μF	≤47μF		≤47μF	≤100μF

ITEM	REQUIREMENT		TEST METHOD	
Dielectric Withstanding Voltage (DWV)	No breakdown or damage		Measuring Voltage NPO: 300% Rated voltage X7R, X5R: 250% Rated voltage Duration: 1 ~ 5 seconds Charge/Discharge Current: 50mA max. (This method excludes high-voltage MLCC)	
Solderability	At least 95% of the terminal electrode is covered by new solder. Visual Appearance: no visible damage		Preheating conditions: 80°C to 120°C; 10~30 seconds	
			Solder Temperature: 235°C ±5°C (Sn/Pb: 63/37) Duration: 2 ±0.5 seconds	Solder Temperature: 245°C ±5°C (Lead-free) Duration: 2 ±0.5 seconds
Termination Adhesion (0201~1812 sizes)	No visible damage		Applied Force: ≤0402, size 2N; ≥0603 size, 5N Duration: 10 ±1 second	
Insulation Resistance	NPO	C≤10nF, Ri≥50,000MΩ C>10nF, Ri•CR >500S	Measuring Voltage: Rated Voltage (Max 500V) Duration: 60 ±5 seconds Test Humidity: ≤75% Test Temperature: 25°C ±3°C Test Current: ≤50mA	
	X7R, X5R	C≤25nF, Ri≥10,000MΩ C>25nF, Ri•CR >100S		
Resistance to Soldering Heat	Item	NPO	X7R, X5R	Preheating conditions: 100°C to 200°C; 1-2 minutes Solder temperature: 265°C ±5°C Duration: 10 ± 1 second Clean the capacitor with solvent and examine it with a 10X(min) microscope Recovery Time: 24 ±2 hours Recovery condition: Room temperature
	ΔC/C	≤±02.5% or ±0.25pF whichever is larger	±15%	
	DF	Same to initial value		
	IR	Same to initial value		
	Appearance: No visible damage At least 95% of the terminal electrode is covered by new solder.			
Temperature Cycle	NPO: ΔC/C: ±1% or ±1pF, whichever is larger X7R, X5R: ΔC/C: ≤±10%		Cycling Times: 5 times, 1 cycle, 4 steps 1 - Low-category temp NPO/X7R/X5R: -55°C for 30 minutes 2 - Room Temperature (+20°C) for 2 - 3 minutes 3 - Up-category temp NPO/X7R: +125°C for 30 minutes X5R: +85°C for 30 minutes 4 - Room Temperature (+20°C) for 2 - 3minutes	
Resistance to Flexure of Substrate (Bending Strength)	Appearance: No visible damage ΔC/C: ≤±10% Class I: ≤±5% or ±0.5pF, whichever is larger Class II: ≤±10%		Test Board: Al2O3 or PCB Warp: 1mm Speed: 1 mm/second The measurement should be made with the board in the bending position	
Humidity Load	NPO: ΔC/C: ±7.5% or ±0.75pF, whichever is larger X7R, X5R: ΔC/C: ≤±12.5% DF: Not more than twice of initial value IR: NPO: Ri≥5,000MΩ; Ri•CR≥50S whichever is smaller X7R, X5R: Ri≥1,000MΩ; Ri•CR≥10S whichever is smaller Appearance: No visible damage		Temperature: 40°C ±2°C Humidity: 90~95% RH Voltage: Rated Voltage Duration: 500 hours Recovery Conditions: Room Temperature Recovery Time: 24 hours (NPO); 48 hours (X7R, X5R)	

AU Automotive Grade Ceramic Capacitors

- WIDE SELECTION OF SIZES (0201~1210)
- HIGH CAPACITANCE IN GIVEN CASE SIZE
- CERTIFIED AEC-Q200



GENERAL SPECIFICATION

	NPO	X7R
Capacitance Range	0.5pF ~ 0.039μF	100pF ~ 1μF
Capacitance Tolerance	≤5pF, B, C ; ≤10pF - C, D ≥10pF - F, G, J	J, K, M
Temperature Characteristic	±30ppm	±15 %
Available Sizes	0201, 0402, 0603, 0805, 1206, 1210	
Operating Temperature	-55°C ~ +125°C	
Rated Voltage (WVDC)	10V, 16V, 25V, 50V, 100V, 250V, 500V, 630V	
Termination	Ni/Sn (Lead-free Termination)	

0201

	NPO	Case	X7R	Case
10V	0.5 ~ 120	L	-----	-
16V	0.5 ~ 120	L	-----	-
25V	0.5 ~ 120	L	-----	-
50V	0.5 ~ 120	L	-----	-

0402

	NPO	Case	X7R	Case
10V	0.5 ~ 1,000	N	100 ~ 10,000	N
16V	0.5 ~ 1,000	N	100 ~ 10,000	N
25V	0.5 ~ 1,000	N	100 ~ 10,000	N
50V	0.5 ~ 1,000	N	100 ~ 10,000	N

0603

	NPO	Case	X7R	Case
10V	0.5 ~ 1,000	S	100 ~ 0.1μF	S
	1,200 ~ 3,300	X		
16V	0.5 ~ 1,000	S	100 ~ 0.1μF	S
	1,200 ~ 3,300	X		
25V	0.5 ~ 1,000	S	100 ~ 0.1μF	S
	1,200 ~ 3,300	X		
50V	0.5 ~ 1,000	S	100 ~ 27,000	S
	1,200 ~ 3,300	X	33,000 ~ 0.1μF	X
100V	0.5 ~ 1,000	S	100 ~ 10,000	S
200V	0.5 ~ 220	S	-----	
	270 ~ 470	X		
250V	0.5 ~ 220	S	-----	
	270 ~ 470	X		

All vales in pF unless noted otherwise.

0805

	NPO	Case	X7R	Case
10V	0.5 ~ 330	A	100 ~ 0.12μF	B
	390 ~ 2,200	B	0.15μF ~ 1.0μF	D
	2,700 ~ 10,000	D	-----	-
16V	0.5 ~ 10,000	A	100 ~ 0.12μF	B
	390 ~ 2,200	B	0.15μF ~ 1.0μF	D
	2,700 ~ 10,000	D	-----	-
25V	0.5 ~ 330	A	100 ~ 0.12μF	B
	390 ~ 2,200	B	0.15μF ~ 1.0μF	D
	2,700 ~ 10,000	D	-----	-
50V	0.5 ~ 330	A	100 ~ 0.1μF	B
	390 ~ 2,200	B	0.12μF ~ 0.22μF	D
	2,700 ~ 10,000	D	-----	-
100V	0.5 ~ 330	A	100 ~ 22,000	B
	390 ~ 2,200	B	27,000 ~ 0.1μF	D
	2,700 ~ 6,800	D	-----	-
200V	0.5 ~ 82	A	100 ~ 82,000	B
	100 ~ 120	B	10,000 ~ 22,000	D
	150 ~ 2,200	D	-----	-
250V	0.5 ~ 82	A	100 ~ 82,000	B
	100 ~ 120	B	10,000 ~ 22,000	D
	150 ~ 2,200	D	-----	-
500V	0.5 ~ 68	A	100 ~ 3,900	B
	82 ~ 100	B	4,700 ~ 10,000	D
	120 ~ 390	D	-----	-
630V	0.5 ~ 68	A	100 ~ 3,900	B
	82 ~ 100	B	4,700 ~ 10,000	D
	120 ~ 390	D	-----	-

1206

	NPO	Case	X7R	Case
10V	1.2 ~ 5,600	B	150 ~ 0.12μF	B
	6,800 ~ 10,000	D	0.15μF ~ 0.39μF	C
	12,000 ~ 39,000	P	0.47μF ~ 1.0μF	J
16V	1.2 ~ 5,600	B	150 ~ 0.12μF	B
	6,800 ~ 10,000	D	0.15μF ~ 0.39μF	C
	12,000 ~ 39,000	P	0.47μF ~ 1.0μF	J
25V	1.2 ~ 5,600	B	150 ~ 0.12μF	B
	6,800 ~ 10,000	D	0.15μF ~ 0.33μF	C
	12,000 ~ 39,000	P	0.39μF ~ 1.0μF	J
50V	1.2 ~ 5,600	B	150 ~ 0.12μF	B
	6,800 ~ 10,000	D	0.15μF ~ 0.22μF	C
	12,000 ~ 39,000	P	0.27μF ~ 0.33μF	D
	-----	-	0.39μF ~ 1.0μF	P
100V	1.2 ~ 5,600	B	150 ~ 68,000	B
	6,800	C	82,000 ~ 0.12μF	D
	8,200 ~ 10,000	D	0.15μF ~ 0.22μF	G
	12,000 ~ 22,000	P	-----	-
200V	1.2 ~ 390	B	100 ~ 22,000	D
	470 ~ 1,200	C		
	1,500 ~ 4,700	D		
250V	1.2 ~ 220	B	100 ~ 22,000	D
	270 ~ 470	C		
	470 ~ 680	D		
	820 ~ 4,700	G		
500V	1.2 ~ 220	B	100 ~ 10,000	D
	270 ~ 470	C		
	560 ~ 680	D		
	820 ~ 2,200	G		
630V	1.2 ~ 220	B	100 ~ 10,000	D
	270 ~ 470	C		
	560 ~ 680	D		
	820 ~ 2,200	G		

1210

	NPO	Case	X7R	Case
10V	10 ~ 10,000	C	1,000 ~ 0.22μF	C
	12,000 ~ 16,000	D		
	18,000 ~ 33,000	K		
16V	10 ~ 10,000	C	1,000 ~ 0.22μF	C
	12,000 ~ 16,000	D		
	18,000 ~ 33,000	K		
25V	10 ~ 10,000	C	1,000 ~ 0.22μF	C
	12,000 ~ 16,000	D		
	18,000 ~ 33,000	K		
50V	10 ~ 10,000	C	1,000 ~ 0.22μF	C
	12,000 ~ 16,000	D		
	18,000 ~ 33,000	K		
100V	10 ~ 10,000	C	1,000 ~ 0.1μF	C
	12,000 ~ 16,000	D		
	18,000 ~ 33,000	K		
200V	10 ~ 820	C	100 ~ 560	D
	1,000 ~ 3,900	D	680 ~ 39,000	C
	4,700 ~ 10,000	K	47,000	D
250V	10 ~ 820	C	100 ~ 560	D
	1,000 ~ 3,900	D	680 ~ 39,000	C
	4,700 ~ 10,000	K	47,000	D
500V	10 ~ 820	C	100 ~ 22,000	D
	1,000 ~ 3,900	D		
630V	10 ~ 820	C	-----	-
	1,000 ~ 3,900	D		

PACKAGING - T&R

Case Code	A	B	C	D	G	J	K	L	N	P	S	X
Thickness	0.60 ± 0.10	0.80 ± 0.10	0.95 ± 0.10	1.25 ± 0.10	1.60 ± 0.10	1.15 ± 0.15	2.0 ± 0.20	0.30 ± 0.10	0.50 ± 0.10	1.60 ± 0.30	0.80 ± 0.10	0.80 ± 0.15
Qty / Reel	4,000	4,000	3,000	3,000	2,000	3,000	1,000	15,000	10,000	2,000	4,000	4,000

PART NUMBER

AU 1206 N 102 J 500 C T

Series	Size Code	Material	Value	Tolerance	Voltage	Termination	Packaging
AU	0201 0402 0603 0805 1206 1210	N = NPO B = X7R	1R5 = 1.5pF 100 = 10pF 101 = 100pF 102 = 1,000pF 103 = 0.01μF 104 = 0.1μF	B = ±0.1pF C = ±0.25p D = ±0.5pF F = 1% G = 2% J = 5% K = 10% M = 20%	100 = 10V 160 = 16V 250 = 25V 500 = 50V 101 = 100V 201 = 200V 251 = 250V 501 = 500V 631 = 630V	C = Cu/Ni/Sn	T = T&R 7" reel

LEAD FREE
All AU Series ceramic parts are RoHS & REACH Compliant, Matte Tin

S2 X1 / Y2 Safety Certified

- HIGH VOLTAGE IN A GIVEN CASE SIZE
- HIGH STABILITY AND RELIABILITY



GENERAL SPECIFICATION

	NPO	X7R
Capacitance Range	4pF ~ 680pF	100pF ~ 4,700pF
Insulation Resistance at Ur	≥10GΩ	
Temperature Characteristic	±30ppm	±15 %
Capacitance Tolerance	J, K	
Operating Temperature	-55°C ~ +125°C	
Rated Voltage (WVAC)	250Vrms	
Dielectric Withstanding Strength	1500VAC	
Peak Impulse Voltage	5000V	
Termination	Ni/Sn (Lead-free Termination)	
Certified Number	TUV: R500021351, R50118359, R50195920; UL: E250427, R182369	

1808

Rated V (VDC)	Peak Impulse Volt.	NPO	Case	X7R	Case
3KV	5KV	4 ~ 33	F	100 ~ 220	G
		39 ~ 82	G	270 ~ 1,000	K
		100 ~ 150	K	-----	-

1812

Rated V (VDC)	Peak Impulse Volt.	NPO	Case	X7R	Case
3KV	5KV	10 ~ 180	D	150 ~ 560	G
		220 ~ 470	K	680 ~ 8200	K
		-----	-	1,000	M

2211

All vales in pF unless noted otherwise.

Rated V (VDC)	Peak Impulse Volt.	NPO	Case	X7R	Case
3KV	5KV	4 ~ 100	K	150 ~ 390	G
		120 ~ 680	M	470 ~ 820	K
		-----	-	1,000 ~ 2,200	M
	6KV	4 ~ 56	K	-----	-
		68 ~ 82	M	-----	-
		100	U	-----	-

2220

Rated V (VDC)	Peak Impulse Volt.	NPO	Case	X7R	Case
3KV	5KV	-----	-	180 ~ 1,000	K
		-----	-	1,200 ~ 4,700	M

PACKAGING - T&R

Case Code	D	F	G	K	M	U
Thickness	1.25 ± 0.10	1.10 ± 0.15	1.60 ± 0.20	2.00 ± 0.20	2.50 ± 0.30	2.80 ± 0.30
Qty / Reel	3,000	2,000	1,000	1,000	500	500

PART NUMBER

S2 1808 N 102 J 302 C T

Series	Size Code	Material	Value	Tolerance	Voltage	Termination	Packaging
S2	1808 1812 2220 2211	N = NPO B = X7R	4R0 = 4pF 100 = 10pF 101 = 100pF 472 = 4,700pF	J = 5% K = 10%	302 = 3000V 602 = 6000V	C = Cu/Ni/Sn L = Ag/Ni/Sn	T = T&R 7" reel

S3 X2/Y3 Safety Certified

- HIGH VOLTAGE IN A GIVEN CASE SIZE
- HIGH STABILITY AND RELIABILITY



GENERAL SPECIFICATION

	NPO	X7R
Capacitance Range	3.9pF ~ 1,000pF	150pF ~ 5,600pF
Insulation Resistance at Ur	≥10GΩ	
Capacitance Characteristic	±30ppm	±15%
Q/DF (Tan δ)	Cap ≤30pF : Q≥400+20C	Tan δ ≤2.5%
Capacitance Tolerance	J, K	K, M
Operating Temperature	-55°C ~ +125°C	
Rated Voltage (WVAC)	250Vrms	
Dielectric Withstanding Strength	1500VAC	
Peak Impulse Voltage (X2)	2500V	
Termination	Ni/Sn (Lead-free Termination)	
Certified Number	TUV: R500021351, R50118359, R50195920; UL: E250427, R182369	

1808

Rated Voltage (VDC)	NPO	Case	X7R	Case
2,000	10 ~ 33	F	150 ~ 820	G
	39 ~ 82	G	1,000 ~ 2,200	K
	100 ~ 1,000	K	-----	-
3,000	3.9 ~ 33	F	330 ~ 820	G
	39 ~ 82	G	1,000	K
	100 ~ 270	K	-----	-

1812

All vales in pF unless noted otherwise.

Rated Voltage (VDC)	NPO	Case	X7R	Case
2,000	-----	-	270 ~ 1,200	G
	-----	-	1,500 ~ 1,800	K
	-----	-	2,200 ~ 5,600	M
3,000	10 ~ 560	D	680 ~ 1,000	G
	680 ~ 1,000	K	-----	-

PACKAGING - T&R

Case Code	D	F	G	K	M
Thickness	1.25 ± 0.10	1.10 ± 0.15	1.60 ± 0.20	2.00 ± 0.20	2.50 ± 0.30
Qty / Reel	3,000	2,000	1,000	1,000	500

PART NUMBER

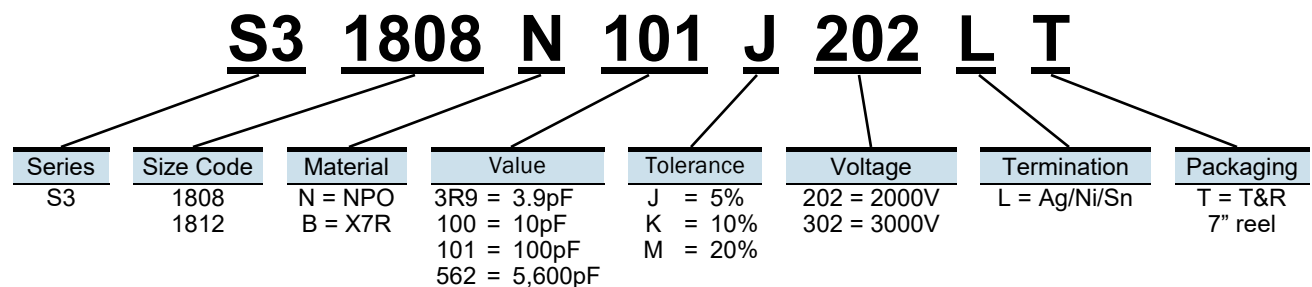

SG Soft Termination Capacitors

- MLCC's TERMINATIONS BUILT WITH A SOFT & FLEXIBLE POLYMER TO WITHSTAND HIGH BENDING STRESS IN SMT LINES
- Cu POLYMER



GENERAL SPECIFICATION

	X7R
Capacitance Range	100pF ~ 47μF
Capacitance Tolerance	J, K, M
Temperature Characteristic	±15 %
Available Sizes	0402, 0603, 0805, 1206
Operating Temperature	-55°C ~ +125°C
Rated Voltage (WVDC)	6.3V, 10V, 16V, 25V, 50V, 100V, 200V, 250V, 500V, 630V, 1KV, 2KV, 3KV
Termination	Ni/Sn (Lead-free Termination)

0402, 0603

	NPO	Case
10V	100 ~ 0.22μF	s
16V	100 ~ 0.220μF	s
25V	100 ~ 0.10μF	s
	0.12uf ~ 0.22μF	x
50V	100 ~ 27,000	s
	33,000 ~ 0.10μF	x
100V	100 ~ 10,000	s
	12,000 ~ 0.10μF	x
200V	100 ~ 10,000	x
250V	100 ~ 10,000	x

0805

	NPO	Case
10V	100 ~ 0.22μF	D
	0.27μF ~ 0.82μF	I
16V	100 ~ 0.22μF	D
	0.27μF ~ 0.82μF	I
25V	100 ~ 0.22μF	D
	0.27μF ~ 0.82μF	I
50V	100 ~ 0.22μF	D
	0.27μF ~ 0.47μF	I
100V	100 ~ 0.10μF	D
	0.12μF ~ 0.22μF	I
200V	100 ~ 0.10μF	D
250V	100 ~ 68,000	D
500V	100 ~ 3,900	B
	4,700 ~ 33,000	D
630V	100 ~ 3,900	B
	4,700 ~ 27,000	D
1000V	100 ~ 1,200	B
	1,800 ~ 2,200	D

1206

	NPO	Case
10V	100 ~ 0.12μF	D
	0.15μF ~ 0.39μF	C
	0.47μF ~ 1.0μF	J
16V	100 ~ 0.12μF	D
	0.15μF ~ 0.39μF	C
	0.47μF ~ 1.0μF	J
25V	100 ~ 0.12μF	D
	0.15μF ~ 0.33μF	C
	0.39μF ~ 1.0μF	J
50V	100 ~ 0.12μF	D
	0.15μF ~ 0.22μF	C
	0.27μF ~ 0.33μF	D
	0.39μF ~ 1.0μF	P
100V	100 ~ 0.10μF	D
	0.15μF ~ 0.47μF	G
	0.56μF ~ 0.82μF	P
200V	100 ~ 27,000	D
	33,000 ~ 0.1μF	G
250V	100 ~ 27,000	D
	33,000 ~ 0.1μF	G
400V	68,000 ~ 0.1μF	G
450V	68,000 ~ 0.1μF	G
500V	100 ~ 18,000	D
	22,000 ~ 56,000	G
630V	100 ~ 18,000	D
	22,000 ~ 56,000	G
1000V	100 ~ 10,000	D
	12,000 ~ 15,000	G
1500V	100 ~ 680	D
	820 ~ 10,000	G
2000V	100 ~ 680	D
	820 ~ 3,300	G

All vales in pF unless noted otherwise.

CONSTRUCTION

No.	Name	X7R
1	Ceramic Material	BaTiO ₃ based
2	Inner Electrode	Ni
3	Inner Layer	Cu + Cu Polymer
4	Termination Middle Layer	Ni
5	Outer Layer	Sn

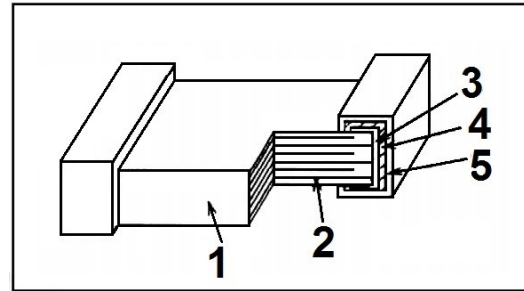

DIMENSIONS & PACKAGING - T&R - 7"

Size	L	W	T / Symbol	Rmk.	M _B	Qty T&R - 7"
0603	1.60 ±0.20	0.80 ±0.10	0.80 ±0.70	S	0.40 ±0.15	4,000
	1.60 ±0.30	0.80 ±0.30	0.80 ±0.30	X		4,000
0805	2.00 ±0.20	1.25 ±0.10	0.80 ±0.10	B	0.50 ±0.20	4,000
			1.25 ±0.10	D #		3,000
	2.00 ±0.30	1.25 ±0.30	1.25 ±0.30	I #		3,000
1206	3.20 +0.4/-0.1	1.60 ±0.15	0.80 ±0.10	B	0.60 ±0.20 (0.50 ±0.25)*	4,000
			0.95 ±0.10	C #		3,000
			1.15 ±0.15	J #		3,000
			1.25 ±0.10	D #		3,000
	3.20 +0.4/-0.1	1.60 ±0.20	1.60 ±0.20	G #		2,000
	3.20 ±0.50	1.60 ±0.50	1.60 ±0.50	P #		2,000

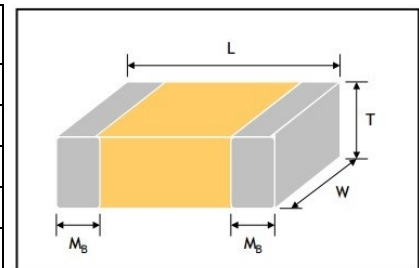

All dimensions in mm.
 # Reflow soldering only is recommended.
 * For 1206 ≥ 1,000v products.

PART NUMBER

SG 0805 B 331 J 202 C T

Series	Size Code	Material	Value	Tolerance	Voltage	Termination	Packaging
SG	0603 0805 1206	B = X7R	101 = 100pF 562 = 5,600pF 333 = 0.033µF 104 = 0.1µF 105 = 1.0µF	J = 5% K = 10% M = 20%	100 = 10V 160 = 16V 500 = 50V 101 = 100V 501 = 500V 631 = 630V 102 = 1000V 152 = 1500V 202 = 2000V	C = Cu/Ni/Sn	T = T&R 7" reel

SG Series parts are
RoHS & REACH Compliant

SH Soft Termination Capacitors

- MLCC's TERMINATIONS BUILT WITH A SOFT & FLEXIBLE POLYMER TO WITHSTAND HIGH BENDING STRESS IN SMT LINES
- Ag POLYMER



GENERAL SPECIFICATION

	NPO	X7R	X5R	Y5V*
Capacitance Range	0.1pF ~ 0.082μF	100pF ~ 47μF	0.027μF ~ 10μF	0.01μF ~ 4.7μF
Capacitance Tolerance	≤5pF - B, C ; ≤10pF - C, D ≥10pF - F, G, J, K	K, M		Z
Temperature Characteristic	±30ppm	±15 %		+30/-80 %
Available Sizes	0402 ~ 2225		0402 ~ 1210	0402 ~ 0603
Operating Temperature	-55°C ~ +125°C		-55°C ~ +85°C	-25°C ~ +85°C
Rated Voltage (WVDC)	6.3V ~ 3KV			
Termination	Ni/Sn (Lead-free Termination)			

0402

	NPO	Case	X7R	Case
10V	0.1 ~ 1,000	E	100 ~ 0.10μF	E
16V	0.1 ~ 1,000	E	100 ~ 0.10μF	E
25V	0.1 ~ 1,000	E	100 ~ 47,000	E
50V	0.1 ~ 1,000	E	100 ~ 10,000	E
100V	0.5 ~ 220	E	100 ~ 4,700	E

0805

	NPO	Case	X7R	Case
10V	0.5 ~ 330	A	100 ~ 0.22μF	D
	390 ~ 2,200	B	0.27μF ~ 2.2μF	I
	2,700 ~ 10,000	D	-----	-
16V	0.5 ~ 330	A	100 ~ 0.22μF	D
	390 ~ 2,200	B	0.27μF ~ 4.7μF	I
	2,700 ~ 10,000	D	-----	-
25V	0.5 ~ 330	A	100 ~ 0.22μF	D
	390 ~ 2,200	B	0.27μF ~ 2.2μF	I
	2,700 ~ 10,000	D	-----	-
50V	0.5 ~ 330	A	100 ~ 0.22μF	B
	390 ~ 2,200	B	0.27μF ~ 0.47μF	I
	2,700 ~ 10,000	D	1.0μF	I
100V	0.5 ~ 330	A	100 ~ 0.1μF	D
	390 ~ 2,200	B	0.12μF ~ 0.22μF	I
	2,700 ~ 6,800	D	-----	-
200V	0.5 ~ 120	A	100 ~ 0.1μF	D
	150 ~ 180	B		
	220 ~ 2,200	D		
250V	0.5 ~ 82	A	100 ~ 68,000	D
	100 ~ 120	B		
	150 ~ 2,200	D		
500V	0.5 ~ 68	A	100 ~ 3,900	B
	82 ~ 100	B	4,700 ~ 33,000	D
	120 ~ 390	D	-----	-
	470 ~ 1,000	I	-----	-
630V	0.5 ~ 68	A	100 ~ 3,900	B
	82 ~ 100	B	4,700 ~ 27,000	D
	120 ~ 390	D	-----	-
	470 ~ 1,000	I	-----	-
1000V	0.5 ~ 390	D	100 ~ 1,200	B
		D	1,500 ~ 2,200	D

0603

	NPO	Case	X7R	Case
10V	0.3 ~ 1,000	s	100 ~ 0.22μF	s
	1,200 ~ 3,300	x	0.27μF ~ 1.0μF	x
16V	0.3 ~ 1,000	s	100 ~ 0.22μF	s
	1,200 ~ 3,300	x	0.27μF ~ 1.0μF	x
25V	0.3 ~ 1,000	s	100 ~ 0.10μF	s
	1,200 ~ 3,300	x	0.12μF ~ 0.47μF	x
50V	0.3 ~ 1,000	s	100 ~ 0.27μF	s
	1,200 ~ 3,300	x	33,000 ~ 0.1μF	x
100V	0.5 ~ 1,000	s	100 ~ 10,000	s
		x	12,000 ~ 0.1μF	x
200V	0.5 ~ 220	s	100 ~ 10,000	x
	270 ~ 470	x		
250V	0.5 ~ 220	s	100 ~ 10,000	x
	270 ~ 470	x		

All values in pF unless noted otherwise.

1206

	NPO	Case	X7R	Case
10V	1.2 ~ 5,600	B	150 ~ 0.12μF	D
	6,800	C	0.15μF ~ 0.39μF	C
	8,200 ~ 10,000	D	0.47μF ~ 2.2μF	J
	12,000 ~ 39,000	P	3.3μF ~ 22μF	P
16V	1.2 ~ 5,600	B	150 ~ 0.12μF	D
	6,800	C	0.15μF ~ 0.39μF	C
	8,200 ~ 10,000	D	0.47μF ~ 2.2μF	J
	12,000 ~ 39,000	P	3.3μF ~ 10μF	P
25V	1.2 ~ 5,600	B	150 ~ 0.12μF	D
	6,800	C	0.15μF ~ 0.33μF	C
	8,200 ~ 10,000	D	0.39μF ~ 1.0μF	J
	12,000 ~ 39,000	P	1.5μF ~ 10μF	P
50V	1.5 ~ 5,600	B	150 ~ 0.12μF	D
	6,800	C	0.15μF ~ 0.22μF	C
	8,200 ~ 10,000	D	0.27μF ~ 0.33μF	D
	12,000 ~ 39,000	P	0.39μF ~ 2.2μF	P
100V	1.2 ~ 5,600	B	150 ~ 0.12μF	D
	6,800	C	0.15μF ~ 0.47μF	G
	8,200 ~ 10,000	D	0.56μF ~ 1.0μF	P
	12,000 ~ 22,000	P	-----	-
200V	1.5 ~ 390	B	100 ~ 27,000	D
	470 ~ 1,200	C	33,000 ~ 0.1μF	G
	1,500 ~ 4,700	D	-----	-
250V	1.5 ~ 220	B	100 ~ 27,000	D
	270 ~ 470	C		
	560 ~ 680	D	33,000 ~ 0.1μF	G
	820 ~ 4,700	G		
500V	1.5 ~ 220	B	100 ~ 18,000	D
	270 ~ 470	C		
	560 ~ 680	D	22,000 ~ 56,000	G
	820 ~ 4,700	G		
630V	1.5 ~ 220	B	100 ~ 18,000	D
	270 ~ 470	C		
	560 ~ 680	D	22,000 ~ 56,000	G
	820 ~ 4,700	G		
1000v	1.5 ~ 39	B	100 ~ 10,000	D
	47 ~ 68	C		
	82 ~ 150	D	12,000 ~ 15,000	G
	180 ~ 1,000	G		
1500V	1.5 ~ 27	B	100 ~ 680	D
	33 ~ 47	C		
	56 ~ 100	D	820 ~ 10,000	G
	120 ~ 220	G		
	270 ~ 390	P		
2000V	1.5 ~ 27	B	100 ~ 680	D
	33 ~ 47	C		
	56 ~ 100	D	820 ~ 3,300	G
	120 ~ 220	G		
	270 ~ 390	P		

1210

	NPO	Case	X7R	Case
10V	10 ~ 10,000	C	1,000 ~ 0.47μF	C
			0.56μF ~ 1.0μF	D
	12,000 ~ 15,000	D	1.5μF ~ 3.3μF	G
			4,700	K
16V	10 ~ 10,000	C	1,000 ~ 0.47μF	C
			0.56μF ~ 1.0μF	D
	12,000 ~ 15,000	D	1.5μF ~ 10μF	G
			22μF	K
25V	10 ~ 10,000	C	1,000 ~ 0.47μF	C
			0.56μF ~ 1.0μF	D
	12,000 ~ 15,000	D	1.5μF ~ 3.3μF	G
			4,7μF	K
50V	10 ~ 10,000	C	1,000 ~ 0.27μF	C
	12,000 ~ 15,000	D	0.33μF ~ 1.0μF	D
	-----	-	1.5μF ~ 10μF	M
100V	10 ~ 10,000	C	1,000 ~ 0.12μF	C
			0.15μF ~ 0.22μF	D
			0.27μF ~ 0.33μF	G
	12,000 ~ 15,000	D	0.39μF ~ 0.56μF	M
			0.68μF ~ 1.0μF	K
		1.5μF ~ 10μF	M	
200V	10 ~ 820	C	1,000 ~ 39,000	C
	1,000 ~ 3,900	D	47,000 ~ 56,000	D
	4,700 ~ 10,000	G	68,000 ~ 0.12uF	G
	-----	-	0.15μF ~ 0.68uF	M
	-----	-	-----	-
250V	10 ~ 820	C	1,000 ~ 39,000	C
	1,000 ~ 3,900	D	47,000 ~ 56,000	D
	4,700 ~ 10,000	G	68,000 ~ 0.12uF	G
	-----	-	0.15μF ~ 0.68uF	M
500V	10 ~ 820	C	100 ~ 22,000	D
			27,000 ~ 56,000	G
	1,000 ~ 3,900	D	68,000 ~ 0.1μF	K
		-----	-	
630V	10 ~ 820	C	100 ~ 22,000	D
			27,000 ~ 56,000	G
	1,000 ~ 3,900	D	68,000 ~ 0.1μF	K
		-----	-	
1000V	10 ~ 82	C	100 ~ 3,300	D
	100 ~ 180	D	3,900 ~ 33,000	G
	220 ~ 1,200	G	39,000	K
	1,500	K	47,000	M
	1,800 ~ 3,900	M	-----	-
1500V	10 ~ 47	C	100 ~ 1,000	D
	56 ~ 120	D		
	150 ~ 220	G	1,200 ~ 8,200	M
	270 ~ 220	K		
	390 ~ 470	M		
		-----	-	
2000V	10 ~ 47	C	100 ~ 1,000	D
	56 ~ 120	D		
	150 ~ 220	G	1,200 ~ 8,200	M
	270 ~ 330	K		
	390 ~ 470	M		
		-----	-	

1808

	NPO	Case	X7R	Case
500V	2.2 ~ 220	D	150 ~ 47,000	D
	270 ~ 3,300	K	5,600 ~ 82,000	K
630V	2.2 ~ 220	D	150 ~ 47,000	D
	270 ~ 3,300	K	5,600 ~ 82,000	K
1000V	2.2 ~ 220	D	150 ~ 4,700	D
	270 ~ 2,200	K	5,600 ~ 56,000	K
	1,200 ~ 1,500	G	-----	-
1500V	2.2 ~ 120	D	150 ~ 820	D
	150 ~ 680	K	1,000 ~ 6,800	K
2000V	2.2 ~ 120	D	150 ~ 820	D
	150 ~ 680	K		
	820	D	1,000 ~ 6,800	K
	1,000	G		
3000V	2.2 ~ 82	D	150 ~ 270	D
	100 ~ 390	K	330 ~ 1,800	K

1812

	NPO	Case	X7R	Case
10V	10 ~ 33,000	D	1,000 ~ 1.0 μ F	D
16V	10 ~ 33,000	D	1,000 ~ 1.0 μ F	D
25V	10 ~ 33,000	D	1,000 ~ 1.0 μ F	D
50V	10 ~ 33,000	D	1,000 ~ 0.56 μ F	D
			0.68 μ F ~ 1.0 μ F	K
			2.2 μ F	M
100V	10 ~ 33,000	D	1,000 ~ 0.39 μ F	D
			0.47 μ F ~ 1.5 μ F	K
			2.2 μ F	M
200V	10 ~ 6,800	D	270 ~ 0.12 μ F	D
			0.15 μ F ~ 0.47 μ F	K
			0.56 μ F ~ 1.0 μ F	M
250V	10 ~ 6,800	D	270 ~ 0.12 μ F	D
			0.15 μ F ~ 0.47 μ F	K
			0.56 μ F ~ 1.0 μ F	M
500V	10 ~ 10,000	D	270 ~ 47,000	D
	12,000 ~ 15,000	G	56,000 ~ 0.10 μ F	K
	18,000 ~ 22,000	K	0.12 μ F ~ 0.47 μ F	M
630V	10 ~ 10,000	D	270 ~ 47,000	D
	12,000 ~ 15,000	G	56,000 ~ 0.10 μ F	K
	18,000 ~ 22,000	K	0.12 μ F ~ 0.22 μ F	M
1000V	10 ~ 390	D	270 ~ 10,000	D
	470 ~ 3,300	K	12,000 ~ 15,000	K
	3,900	M	18,000 ~ 0.10 μ F	M
1500V	10 ~ 220	D	270 ~ 1,500	D
		G	1,800 ~ 2,700	G
	270 ~ 1,000	K	3,300 ~ 4,700	K
2000V	10 ~ 220	D	270 ~ 1,500	D
		G	1,800 ~ 2,700	G
	270 ~ 1,000	K	3,300 ~ 4,700	K
3000V	10 ~ 150	D	270 ~ 1,500	K
		K	1,800 ~ 6,800	M
	180 ~ 470	K	1,800 ~ 6,800	M

1825

	NPO	Case	X7R	Case
100V	10 ~ 68,000	K	-----	-
	82,000 ~ 0.1 μ F	M		
200V	10 ~ 33,000	K	-----	-
	56,000 ~ 0.1 μ F	M		
250V	10 ~ 33,000	K	1,000 ~ 1.0 μ F	K
	56,000 ~ 0.1 μ F	M		
500V	10 ~ 33,000	K	1,000 ~ 0.47 μ F	K
	39,000	M	0.56 μ F	M
630V	10 ~ 33,000	K	1,000 ~ 0.47 μ F	K
	39,000	M	0.56 μ F	M
	39,000 ~ 68,000	-	-----	-
1000V	10 ~ 3,300	K	1,000 ~ 68,000	K
	3,900 ~ 10,000	M	82,000 ~ 0.1 μ F	M
2000V	10 ~ 1,200	K	1,000 ~ 10,000	K
	1,500 ~ 4,700	M	12,000 ~ 22,000	M
	-----	-	27,000 ~ 47,000	U
3000V	10 ~ 560	K	1,000 ~ 4,700	K
	680 ~ 1,000	M	5,600 ~ 10,000	M
	-----	-	12,000 ~ 18,000	U

2220

	NPO	Case	X7R	Case
25V	-----	-	1,000 ~ 2.2 μ F	K
50V	-----	-	1,000 ~ 4.7 μ F	K
			6.8 μ F	M
			10 μ F	U
100V	100 ~ 68,000	K	1,000 ~ 3.3 μ F	K
	82,000 ~ 0.1 μ F	M	4.7 μ F	M
	-----	-	6.8 μ F ~ 10 μ F	U
200V	10 ~ 39,000	K	-----	-
	47,000 ~ 68,000	M		
	-----	-		
250V	10 ~ 39,000	K	1,000 ~ 1.0 μ F	K
	47,000 ~ 68,000	M	1.5 μ F ~ 2.2 μ F	M
500V	10 ~ 33,000	K	1,000 ~ 0.47 μ F	K
	39,000 ~ 47,000	M	0.56 μ F ~ 0.68 μ F	M
	-----	-	0.82 μ F ~ 1.0 μ F	U
630V	10 ~ 22,000	K	1,000 ~ 0.47 μ F	K
	-----	-	0.56 μ F ~ 0.68 μ F	M
	-----	-	0.82 μ F ~ 1.0 μ F	U
1000V	10 ~ 1,000	K	1,000 ~ 56,000	K
	1,200 ~ 10,000	M	68,000 ~ 0.12 μ F	M
	-----	-	0.15 μ F ~ 0.22 μ F	U
2000V	10 ~ 1,000	K	1,000 ~ 6,800	K
	1,200 ~ 4,700	M	8,200 ~ 15,000	M
	-----	-	18,000 ~ 56,000	U
3000V	10 ~ 270	K	1,000 ~ 5,600	K
	330 ~ 1,500	M	6,800 ~ 10,000	M
	-----	-	12,000 ~ 18,000	U

2225

	NPO	Case	X7R	Case
100V	10 ~ 68,000	K	-----	-
	82,000 ~ 1.0 μ F	M		
200V	10 ~ 47,000	K	-----	-
	56,000 ~ 1.0 μ F	M		
250V	10 ~ 47,000	K	-----	-
	56,000 ~ 1.0 μ F	M		
500V	10 ~ 47,000	K	1,000 ~ 0.56 μ F	K
	56,000 ~ 82,000	M		
630V	10 ~ 47,000	K	1,000 ~ 0.56 μ F	K
	56,000 ~ 68,000	M		
1000V	10 ~ 4,700	K	1,000 ~ 0.10 μ F	K
	5,600 ~ 10,000	M	0.12 μ F ~ 0.22 μ F	U
2000V	10 ~ 680	K	1,000 ~ 10,000	K
	820 ~ 10,000	M	12,000 ~ 33,000	M
	-----	-	39,000 ~ 56,000	U
3000V	10 ~ 680	K	1,000 ~ 4,700	K
	820 ~ 1,000	M	5,600 ~ 15,000	M
	-----	-	18,000	U

0402

	X5R	Case	Y5V*	Case
6.3V	82,000 ~ 0.68 μ F	E	0.22 μ F ~ 0.33 μ F	E
10V	56,000 ~ 0.68 μ F	E	10,000 ~ 0.33 μ F	E
16V	27,000 ~ 0.22 μ F	E	10,000 ~ 0.10 μ F	E
25V	0.10 μ F ~ 0.22 μ F	E	10,000 ~ 0.10 μ F	E
50V	-----	-	10,000 ~ 33,000	E

0603

	X5R	Case	Y5V*	Case
6.3V	0.33 μ F ~ 4.7 μ F	X	-----	-
10V	0.27 μ F ~ 2.2 μ F	X	10,000 ~ 2.2 μ F	S
16V	0.22 μ F ~ 2.2 μ F	X	10,000 ~ 0.47 μ F	S
			0.68 μ F ~ 1.0 μ F	X
25V	0.22 μ f ~ 1.0 μ F	X	10,000 ~ 0.33 μ F	S
50V	-----	-	10,000 ~ 0.22 μ F	S

0805

	X5R	Case	Y5V	Case
6.3V	1.5 μ F ~ 3.3 μ F	I	-----	-
10V	1.5 μ F ~ 3.3 μ F	I	-----	-
16V	1.5 μ F ~ 3.3 μ F	I	-----	-
25V	1.5 μ F ~ 3.3 μ F	I	-----	-

1206

	X5R	Case	Y5V	Case
6.3V	4.7 μ F ~ 10 μ F	P	-----	-
10V	1.5 μ F ~ 2.2 μ F	J	-----	-
	3.3 μ F ~ 10 μ F	P		
16V	1.5 μ F ~ 2.2 μ F	J	-----	-
	3.3 μ F ~ 10 μ F	P		
25V	2.2 μ F ~ 10 μ F	P	-----	-

1210

	X5R	Case	Y5V	Case
6.3V	10 μ F	K	-----	-
10V	1.5 μ F ~ 10 μ F	K	-----	-
16V	1.5 μ F ~ 10 μ F	K	-----	-
25V	4.7 μ F	K	-----	-

* Y5V - NOT FOR NEW DESIGN. Available only while stock is available.

DIMENSIONS & PACKAGING - T&R - 7"

Size	L	W	T / Symbol	Rmk.	M _B	Qty T&R - 7"
0402	1.00 ±0.20	0.50 ±0.20	0.50 ±0.20	E #	0.25 +0.05/-0.1	10,000
0603	1.60 ±0.20	0.80 ±0.10	0.80 ±0.70	S	0.40 ±0.15	4,000
	1.60 ±0.30	0.80 ±0.30	0.80 ±0.30	X		4,000
0805	2.00 ±0.20	1.25 ±0.10	0.60 ±0.10	A	0.50 ±0.20	4,000
			0.80 ±0.10	B		4,000
			1.25 ±0.10	D #		3,000
	2.00 ±0.30	1.25 ±0.30	I #	3,000		
1206	3.20 +0.4/-0.1	1.60 ±0.15	0.80 ±0.10	B	0.60 ±0.20 (0.50 ±0.25)*	4,000
			0.95 ±0.10	C #		3,000
			1.15 ±0.15	J #		3,000
			1.25 ±0.10	D #		3,000
	3.20 +0.4/-0.1	1.60 ±0.20	1.60 ±0.20	G #		2,000
3.20 ±0.50	1.60 ±0.50	1.60 ±0.50	P #	2,000		
1210	3.20 ±0.40	2.50 ±0.20	0.95 ±0.10	C #	0.75 ±0.25	3,000
			1.25 ±0.10	D #		3,000
	3.20 ±0.60	2.50 ±0.50	1.60 ±0.20	G #		2,000
			2.00 ±0.20	K #		1,000
			2.50 ±0.50	M #		1,000
1808	4.50 +0.60/-0.4	3.20 ±0.60	1.25 ±0.10	D #	0.50 ±0.25	2,000
			2.00 ±0.20	K #		1,000
1812	4.50 +0.60/-0.4	3.20 ±0.30	1.25 ±0.10	D #	0.75 ±0.25 (0.50 ±0.25)*	2,000
			1.60 ±0.20	G #		1,000
			2.00 ±0.20	K #		1,000
		3.20 ±0.40	2.50 ±0.50	M #		1,000
1825	4.50 +0.60/-0.4	6.30 ±0.40	2.00 ±0.20	K #	0.75 ±0.35	1,000
			2.50 ±0.30	M #		1,000
			2.80 ±0.30	U #		500
2220	5.70 ±0.60	5.00 ±0.40	2.00 ±0.20	K #	0.85 ±0.35	500
			2.50 ±0.30	M #		500
			2.80 ±0.30	U #		500
2225	5.70 ±0.60	6.30 ±0.40	2.00 ±0.20	K #	0.85 ±0.35	500
			2.50 ±0.30	M #		500
			2.80 ±0.30	U #		500

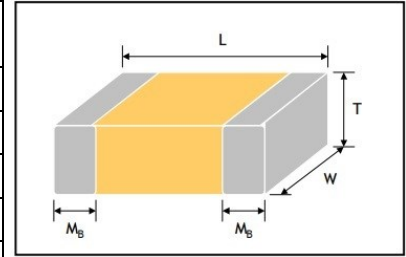

All dimensions in mm.

Reflow soldering only is recommended.

* For 1206 ≥ 1,000v, 1812 ≥ 200v~4,000v products.

CONSTRUCTION

No.	Name	NPO	X7R, X5R, Y5V**
1	Ceramic Material	CaZrO ₃ based	BaTiO ₃ based
2	Inner Electrode	Ni	
3	Termination	Inner Layer	Cu + Ag Polymer
4		Middle Layer	Ni
5		Outer Layer	Sn

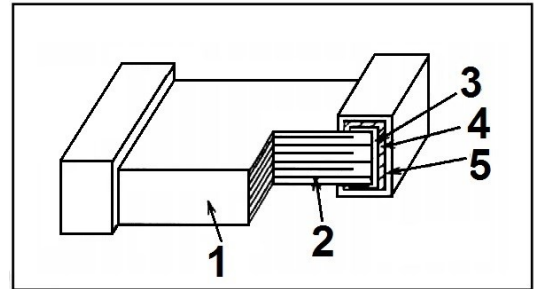

PART NUMBER

SH 1808 N 101 J 202 C T

Series	Size Code	Material	Value	Tolerance	Voltage	Termination	Packaging
SH	0402	N = NPO	3R9 = 3.9pF	B = ±0.1pF	6R3 = 6.3v	C = Ag/Ni/Sn	T = T&R
	0603	B = X7R	100 = 10pF	C = ±0.25pF	100 = 10V		7" reel
	0805	X = X5R	101 = 100pF	D = ±0.5pF	160 = 16V		
	1206	F = Y5V*	562 = 5,600pF	F = 1%	500 = 50V		
	1210		333 = 0.033µF	G = 2%	101 = 100V		
	1808		104 = 0.1µF	J = 5%	501 = 500V		
	1812		105 = 1.0µF	K = 10%	631 = 630V		
	1825			M = 20%	102 = 1000V		
	2220				152 = 1500V		
	2225				202 = 2000V		
					302 = 3000V		

* Y5V - NOT FOR NEW DESIGN. Available only while stock is available.

SH Series parts are
RoHS & REACH Compliant

TC Class 1 - Temperature Compensation Type

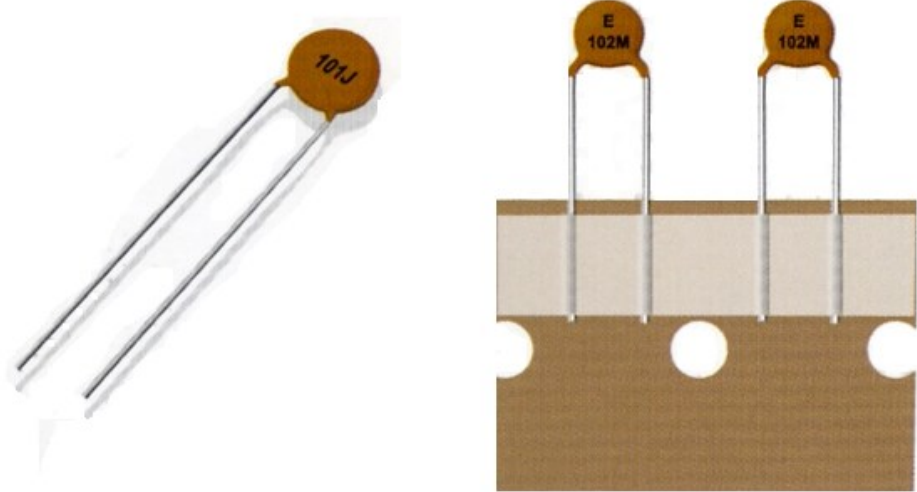

GENERAL SPECIFICATION

Capacitance Range	0.5pF ~ 820pF
Capacitance Tolerance	0.10pF, 0.25pF, 0.5pF, 1%, 5%, 10%
Temperature Characteristics	NPO (CH) $0 \pm 60\text{ppm}/^\circ\text{C}$, SL $+350$ to $1000\text{ppm}/^\circ\text{C}$
Operating Temperature Range	$-25^\circ\text{C} \sim 85^\circ\text{C}$
Rated Working Voltage	50V ~ 6,000V
Q or Dissipation Factor ($\tan \delta$)	$C \geq 30\text{pF}$ $Q \geq 1000$; $C < 30\text{pF}$ $Q \geq 400 + 20^\circ\text{C}$
Insulation Resistance	Greater than $10\text{ G}\Omega$
Dielectric Strength	2.5 times WVDC
Testing Parameters	$1\text{MHz} \pm 100\text{KHz}$ $1.0\text{vrms} \pm 0.2\text{vrms} @ 25^\circ\text{C} \pm 2^\circ\text{C}$

50V & 100V DC *CALL*

Ceramic Coated

500V DC *CALL*

Ceramic Coated

$\varnothing \pm 1\text{mm}$	Temperature Characteristic (pF)	
	NPO*	SL
5	0.5 ~ 47	33 ~ 150
6	50 ~ 68	180 ~ 220
7	75 ~ 100	250 ~ 330
8	120 ~ 150	390
9	180 ~ 200	470 ~ 560
10	220 ~ 270	680 ~ 820
12	300 ~ 330	---

$\varnothing \pm 1\text{mm}$	Temperature Characteristic (pF)	
	NPO*	SL
5	0.5 ~ 15	22 ~ 68
6	18 ~ 33	82 ~ 120
7	39 ~ 56	150 ~ 220
8	68 ~ 82	270 ~ 330
9	100 ~ 120	390 ~ 470
10	150 ~ 180	---
12	200 ~ 220	---

1,000V DC

Ceramic Coated

Ø ±1mm	Temperature Characteristic (pF)	
	NPO	SL
5	1 ~ 10	30 ~ 56
6	12 ~ 33	68 ~ 100
7	39 ~ 50	120 ~ 150
8	56 ~ 68	180 ~ 220
9	75 ~ 90	270 ~ 330
10	100 ~ 120	359 ~ 390
12	150 ~ 180	470 ~ 560
14	200 ~ 220	680 ~ 820

2,000V DC

Epoxy Coated

Ø ±1mm	Temperature Characteristic (pF)	
	NPO	SL
5	1 ~ 20	15 ~ 56
6	22 ~ 30	68 ~ 100
7	33 ~ 39	120 ~ 150
8	47 ~ 50	180
9	56 ~ 68	200 ~ 220
10	75 ~ 82	270 ~ 300
11	90 ~ 100	330
12	110 ~ 120	---
13	150	390

3,000V DC

Epoxy Coated

Ø ±1mm	Temperature Characteristic (pF)	
	NPO	SL
6	1 ~ 18	15 ~ 47
7	20 ~ 30	50 ~ 68
8	33 ~ 39	82 ~ 100
9	47 ~ 56	120
10	62 ~ 68	150 ~ 180
11	72 ~ 82	200 ~ 220
12	90 ~ 100	270
13	110 ~ 120	300 ~ 330
14	150	---

6,000V DC

Epoxy Coated

Ø ±1mm	Temperature Characteristic (pF)	
	NPO	SL
6	---	5 ~ 22
7	---	27 ~ 39
8	---	47 ~ 56
9	---	68
10	---	82
12	---	100 ~ 120
14	---	150

PART NUMBER

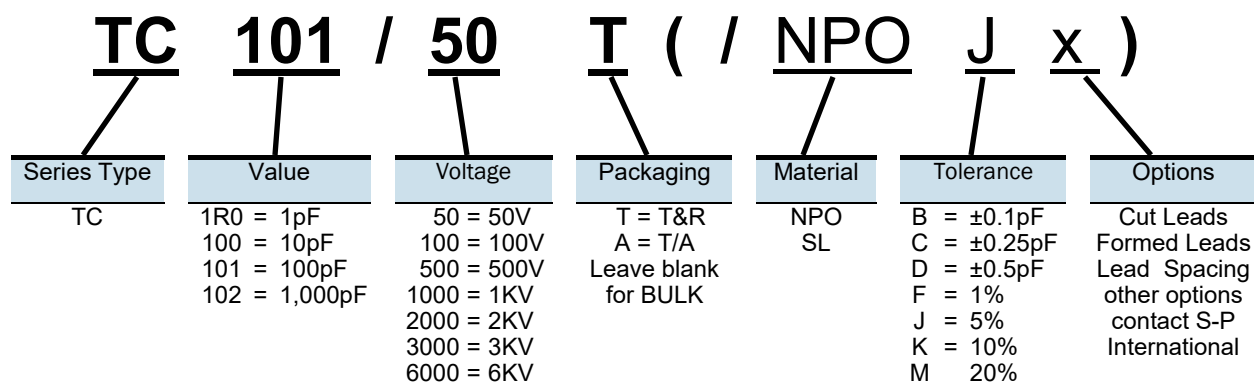

NOTES

- Order by using the basic part number (indicated in **bold**) if material and tolerance are not critical or required. Extended part number (indicated in the parenthesis above) is only used if material and tolerance specification are required. Note that the parenthesis are not used in the actual part number.
- 2% tolerance applicable for NPO parts only
- All products are RoHS & REACH Compliant unless specified otherwise.
- * For NPO under 500v and for values 22pfd or higher, please contact S-P International for availability

HC Class II - Hi-Dielectric Constant Type

GENERAL SPECIFICATION

Capacitance Range	100pF ~ 56,000pF
Capacitance Tolerance	10%, 20%, -20%+80%
Operating Temperature	-25°C ~ 85°C (Y5P), 10°C ~ 85°C (Z5U, Z5V)
Rated Working Voltage	50V ~ 10,000V
Dissipation Factor	Y5P, Z5U tan δ 2.5%; Z5V tan δ 5.0%
Insulation Resistance	10,000M Ω minimum or 200M Ω / μ F whichever is smaller
Dielectric Strength	2 times the rated WVDC
Testing Parameters	1KHz \pm 20%, 1.0vrms \pm 0.2vrms, @ 25°C \pm 2°C (X7R - 50V ~ 500V 2.5 x WVDC; 1KV ~ 10KV 2 x WVDC)

Listed below are the standard ranges and materials available. Other values and materials are available upon request. Contact S-P International or your local distributor for more details.

50V & 100V DC

$\varnothing \pm 1\text{mm}$	Temperature Characteristic (pF)			
	Y5E	Y5P	Z5U	Z5V
4	100 ~ 470	200 ~ 1,000	1,000 ~ 2,700	1,000 ~ 5,000
5	500 ~ 680	1,200 ~ 1,500	3,000 ~ 3,900	5,600 ~ 8,200
6	820 ~ 1,000	1,800 ~ 2,200	4,000 ~ 5,600	10,000
8	1,200 ~ 2,700	2,500 ~ 5,600	6,800 ~ 10,000	22,000 ~ 33,000
10	3,000 ~ 5,600	6,200 ~ 10,000	20,000	40,000 ~ 56,000

500V DC

$\varnothing \pm 1\text{mm}$	Temperature Characteristic (pF)			
	Y5F	Y5P	Z5U	Z5V
5	100 ~ 330	200 ~ 560	1,000 ~ 3,000	2,000 ~ 3,300
6	350 ~ 500	620 ~ 1,000	3,300 ~ 3,900	3,900 ~ 4,700
8	560 ~ 1,200	1,200 ~ 2,200	4,700 ~ 6,800	5,000 ~ 8,200
10	1,500 ~ 2,200	2,500 ~ 3,900	8,200 ~ 10,000	10,000 ~ 15,000
12	2,500 ~ 3,300	4,000 ~ 5,600	12,000 ~ 15,000	-----
14	3,500 ~ 5,000	6,200 ~ 10,000	18,000 ~ 22,000	-----

1,000V DC

$\varnothing \pm 1\text{mm}$	Temperature Characteristic (pF)			
	Y5F	Y5P	Z5U	Z5V
5	-----	100 ~ 500	1,000 ~ 1,200	1,000 ~ 2,200
6	-----	560 ~ 1,000	1,500 ~ 2,200	2,500 ~ 3,300
8	560 ~ 1,200	1,200 ~ 2,000	2,500 ~ 5,000	3,500 ~ 5,600
10	1,500 ~ 2,000	2,200 ~ 3,300	5,600 ~ 8,200	6,200 ~ 12,000
11	2,200 ~ 3,000	3,500 ~ 5,000	10,000 ~ 12,000	15,000
14	3,300 ~ 3,900	5,600 ~ 6,800	15,000 ~ 18,000	18,000 ~ 22,000
16	4,200 ~ 5,600	7,200 ~ 10,000	20,000 ~ 22,000	-----

2,000V DC

Ø ±1mm	Temperature Characteristic (pF)			
	Y5F	Y5E / Y5P	Z5U	Z5V
5	-----	100 - 470	1,000 - 1,200	-----
6	-----	560 - 820	1,500 - 2,200	3,300 - 3,900
7	-----	1,000 - 1,200	2,700 - 3,300	4,700 - 5,000
8	-----	1,500	3,500 - 3,900	5,600 - 6,800
9	-----	1,800 - 2,000	4,700 - 5,600	8,200
10	-----	2,700	-----	10,000
11	-----	3,000 - 3,300	6,800	12,000
12	-----	3,900	-----	-----
13	-----	-----	8,200 - 10,000	-----
14	-----	4,700 - 5,600	-----	-----

3,000V DC

Ø ±1mm	Temperature Characteristic (pF)			
	Y5F	Y5E / Y5P	Z5U	Z5V
6	-----	100 ~ 470	1,000 ~ 1,200	1,800 ~ 2,200
7	-----	680 ~ 820	1,500	2,700 ~ 3,300
8	-----	1,000	1,800 ~ 2,000	3,900
9	-----	1,200	2,200 ~ 2,700	4,700 ~ 5,600
10	-----	1,500	3,000 ~ 3,300	-----
11	-----	1,800	-----	6,800 ~ 8,200
12	-----	2,000 ~ 2,200	3,900 ~ 4,700	10,000
13	-----	-----	-----	-----
14	-----	2,700 ~ 3,300	5,000 ~ 6,800	-----

6,000V DC

Ø ±1mm	Temperature Characteristic (pF)	
	Y5P	Z5U
6	100 ~ 330	-----
7	390 ~ 500	-----
8	560 ~ 680	1,000
10	820	1,500
11	-----	-----
12	1,000	2,200
13	1,500	-----
15	-----	3,300

10,000V DC

Ø ±1mm	Temperature Characteristic (pF)	
	Y5P	Z5U
6	-----	-----
7	100 ~ 120	-----
8	150 ~ 180	-----
10	200 ~ 220	-----
11	270 ~ 330	-----
12	470 ~ 560	-----
13	680	-----
15 - 21	-----	3300 ~ 4700

PART NUMBER

NOTE: See TC Series (page 17) for explanation of part number.

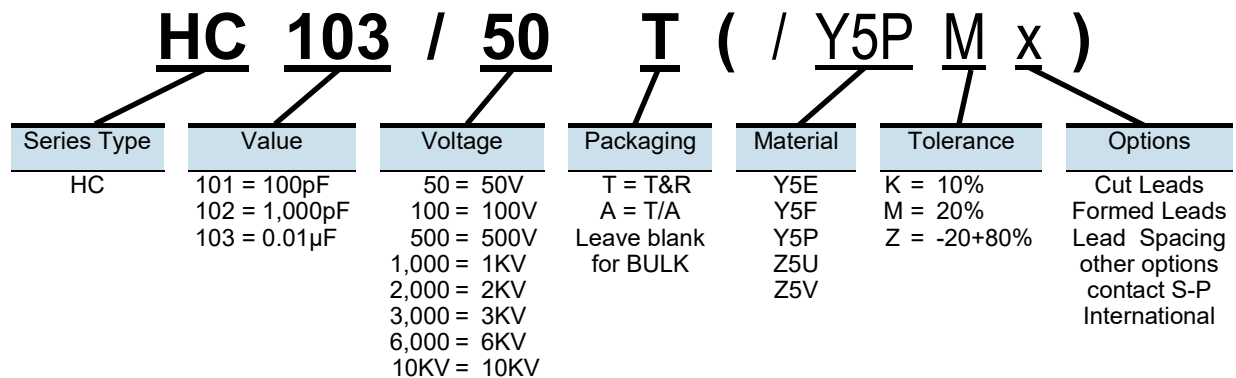

HC X7R

GENERAL SPECIFICATION

Capacitance Range	120pF ~ 10,000pF
Capacitance Tolerance	10%, 20%
Operating Temperature	-55°C ~ +125°C
Rated Working Voltage	50V ~ 2,000V
Dissipation Factor	2.5%
Insulation Resistance	10,000MΩ or 200MΩ / μF whichever is less @ 500VDC for 60 seconds
Dielectric Strength	2 times the rated WVDC

Ø ±1mm	Voltage / (pF)			
	50	500	1,000	2,000
6	150 ~ 1,500	150 ~ 680	-----	-----
7	1,800 ~ 2,200	820 ~ 1,000	220 ~ 470	120 ~ 180
8	2,700 ~ 3,300	1,200 ~ 2,000	560	-----
9	3,900 ~ 4,700	2,200 ~ 3,000	680 ~ 1,800	330 ~ 1,000
11	5,600 ~ 10,000	3,300 ~ 4,700	2,200 ~ 2,700	1,200 ~ 1,500
13	-----	5,600 ~ 6,800	3,000 ~ 4,700	1,800 ~ 2,700
15	-----	8,200 ~ 10,000	-----	3,300

PART NUMBER

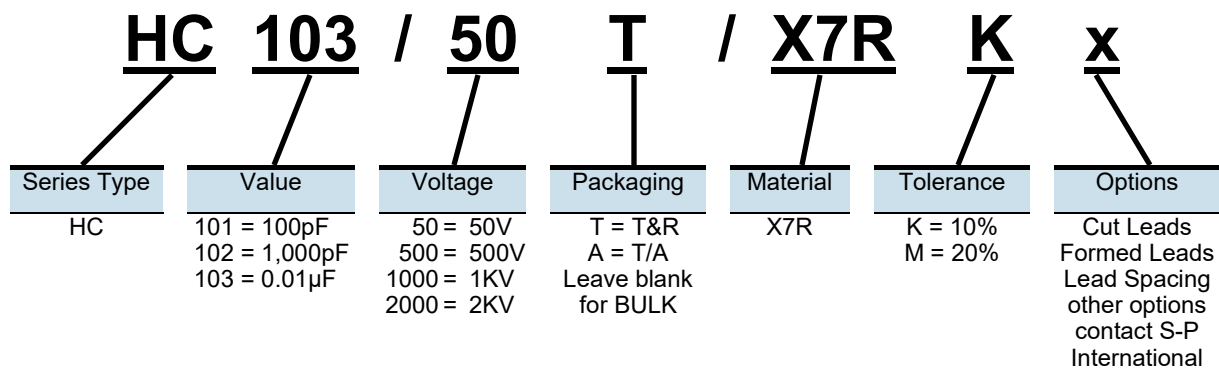

HC Class III - Semi-Conductive Type

GENERAL SPECIFICATION

Capacitance Range	0.001μF ~ 0.22μF
Capacitance Tolerance	10%, 20%, -20% +80%
Operating Temperature	-25°C ~ +85°C
Rated Working Voltage	3V ~ 50V
Dissipation Factor	At 3V DC shall not exceed 5%, above 3V DC shall not exceed 8%
Insulation Resistance	1,000MΩ minimum
Test Frequency	1 KHz at 25°C ± 2°C

3V DC - 16V DC

Ø ±1mm	Temperature Characteristic (μF)			
	Y5R	Y5T	Y5U	Y5V*
5	0.001 ~ 0.022	0.01 ~ 0.033	0.01 ~ 0.033	0.010 ~ 0.047
6	0.027 ~ 0.047	0.047	0.047	0.068 ~ 0.1
8	0.056 ~ 0.1	0.068 ~ 0.1	0.068 ~ 0.1	-----
10	-----	-----	-----	0.22

25V DC

Ø ±1mm	Temperature Characteristic (μF)			
	Y5R	Y5T	Y5U	Y5V*
5	0.001 ~ 0.01	0.01 ~ 0.022	0.01 ~ 0.033	0.01 ~ 0.022
6	0.012 ~ 0.022	0.033 ~ 0.047	0.047	0.033 ~ 0.1
8	0.027 ~ 0.047	0.068 ~ 0.1	0.068 ~ 0.1	-----
10	0.056 ~ 0.1	-----	-----	-----

50V DC

Ø ±1mm	Temperature Characteristic (μF)		
	Y5R	Y5T	Y5V*
5	0.001 ~ 0.0056	-----	0.01 ~ 0.022
6	0.0068 ~ 0.015	0.01 ~ 0.022	0.033 ~ 0.047
8	0.018 ~ 0.022	0.033 ~ 0.047	0.056 ~ 0.1
10	0.0027 ~ 0.047	0.056 ~ 0.1	-----

* Y5V - NOT FOR NEW DESIGN. Available only while stock is available.

PART NUMBER

NOTE: See TC Series (page 17) for explanation of part number

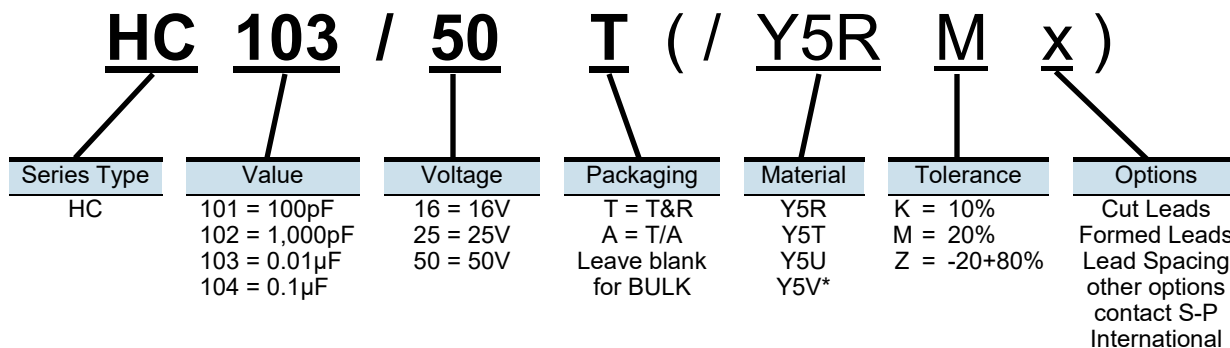

UC \ UA Multilayer (MLCC)

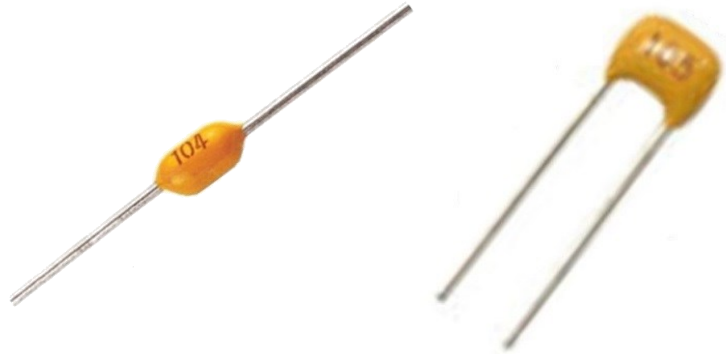

GENERAL SPECIFICATION

	NPO	X7R	X5R	Y5V*
Capacitance Range	1pF ~ 8200pF	1000pF ~ 1 μ F	0.22 μ F ~ 2.2 μ F	0.01 μ F ~ 4.7 μ F
Standard Tolerance *	J, K (C & D tol <10pF)	K, M	K, M	M, Z
Temperature Characteristic	0 \pm 30ppm/ $^{\circ}$ C	\pm 15%	\pm 15%	+22% -82%
Operating Temperature	-55 $^{\circ}$ C ~ +125 $^{\circ}$ C	-55 $^{\circ}$ C ~ +125 $^{\circ}$ C	-55 $^{\circ}$ C ~ +85 $^{\circ}$ C	-30 $^{\circ}$ C ~ +85 $^{\circ}$ C
Rated Working Voltage	50V DC (6.3V, 10V, 16V, 25V, 100V, 200V, 500V Available)			
Dissipation Factor (Q)	C \geq 30pF ; Q \geq 1000 C<30pF ; Q \geq 400 + 20x $^{\circ}$ C	2.5% max. at 1V rms	5%	0.04 max
Insulation Resistance Minimum (25 $^{\circ}$ C Rated Voltage)	Greater than 10G Ω or 500M Ω x μ F, whichever is less			

* Y5V - NOT FOR NEW DESIGN. Available only while stock is available.

CAPACITANCE CHART - AXIAL

Material	Voltage	Standard Tolerance	Capacitance	Dimension (mm)		
			Range (pF)	L	D	d
(C) NPO	50V Voltages 6.3V to 500V available	5%, 10%	1 ~ 1,000	4.2	2.8	0.5
(X) X5R		10%, 20%	330,000 ~ 10 μ F			
(R) X7R		10%, 20%	220 ~ 220,000			
(F) Y5V*		+80% -20%	10,000 ~ 100,000			

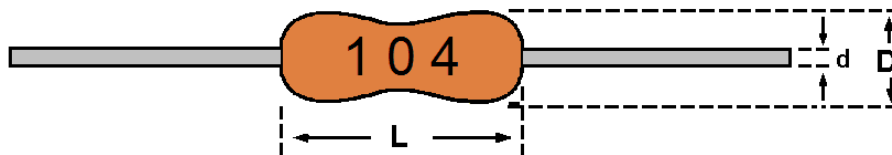

CAPACITANCE CHART - RADIAL

Case Size	Voltage	Material	Capacitance		Dimension (mm)			
			Range (pF)	Tolerance	W	H	T max	LS
15	50	(C) NPO	1 ~ 10,000	J - K	4.5	4.5	3.0	2.5
20			1 ~ 10,000		4.5	4.5	3.0	5.0
18			3,900 ~ 33,000		5.5	5.5	3.5	2.5
21			3,900 ~ 33,000		5.5	5.5	3.5	5.0
15	50	(R) X7R	220 ~ 330,000	K - M	4.5	4.5	3.0	2.5
20			220 ~ 330,000		4.5	4.5	3.0	5.0
18			470,000 ~ 1μF		5.5	5.5	3.5	2.5
21			470,000 ~ 1μF		5.5	5.5	3.5	5.0
15	50	(F) Y5V*	100,000 ~ 1μF	M - Z	4.5	4.5	3.0	2.5
20			100,000 ~ 1μF		4.5	4.5	3.0	5.0
18			2.2μF		5.5	5.5	3.5	2.5
21			2.2μF		5.5	5.5	3.5	5.0

Please contact S- P International regarding other available voltage and tolerances.

Lead Coating "G", where applicable, is 2.0mm Maximum

* Y5V - NOT FOR NEW DESIGN. Available only while stock is available.

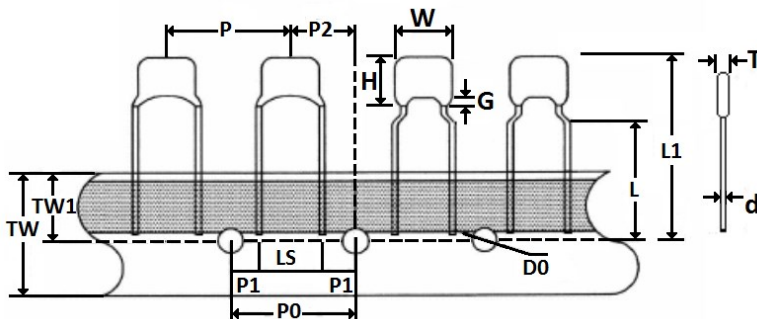

Symbol	LS	P	P0	P1	P2	L
Value	2.5 5.0	12.7	12.7	5.1 3.9	6.35	18 16
Tolerance		±1	±0.3	±0.7	±1	±1.5
Symbol	DO	L1	TW	TW1	d	
Value	4	26.25	18	9	0.55	
Tolerance		±0.2	max	±0.5	±0.5	±0.05

PART NUMBER

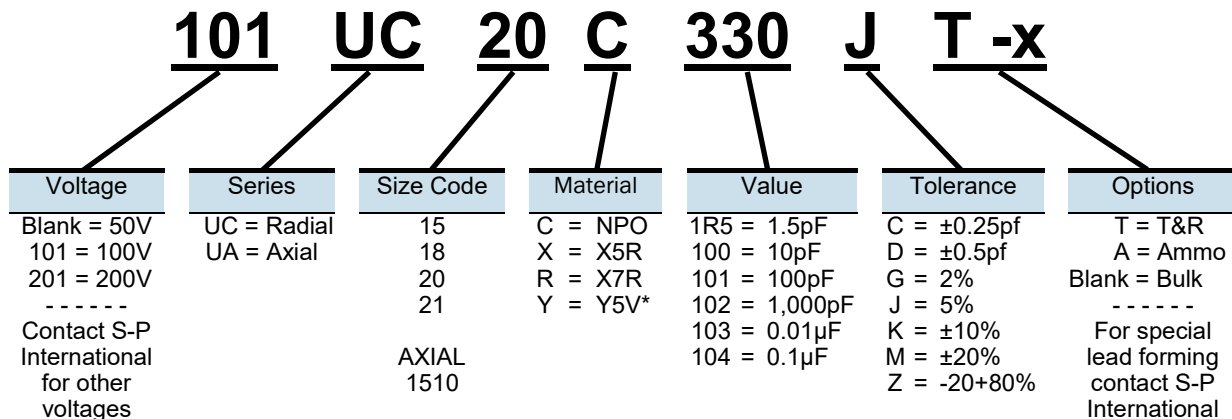

* Y5V - NOT FOR NEW DESIGN. Available only while stock is available.

TAPING SPECIFICATIONS

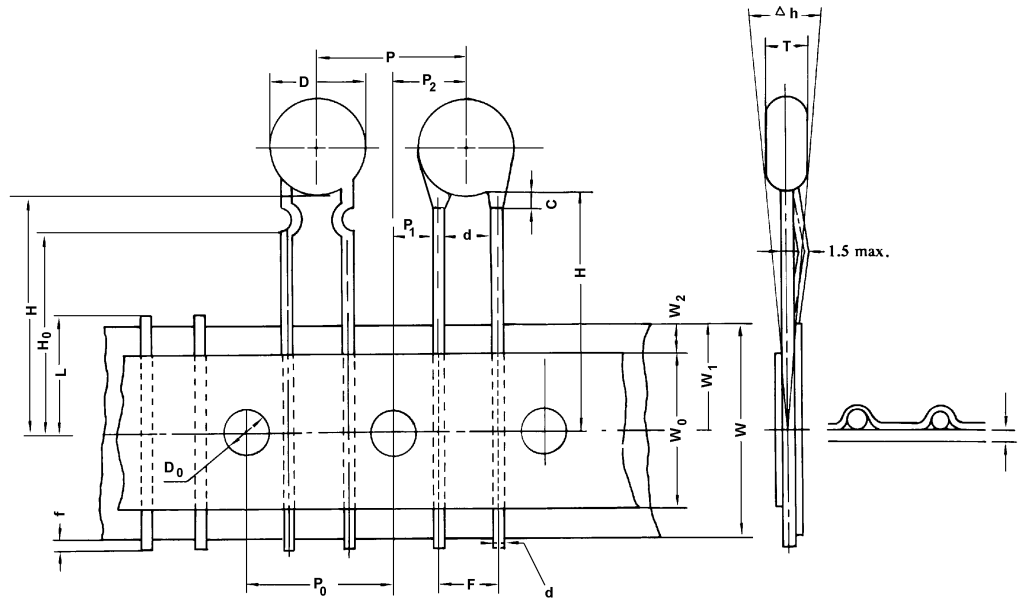

Item	Symbol	Specification		Remarks
Body diameter	D	10.0	maximum	
Body thickness	T	3.5	maximum	
Lead-wire diameter	d	0.55	±0.05	
Pitch of component	P	12.7	±1.0	
Feed hole pitch	P ₀	12.7	±0.5	Cumulative pitch error: ≤2.0mm/20 pitch
Feed hole centre to lead	P ₁	3.85	±0.7	To be measured at bottom of clinch
Hole center to component centre	P ₂	6.35	±1.3	
Lead to lead distance	F	5.0	±0.8	
Component alignment, F-R	Δh	0	±2.0	
Tape width	W	18.0	±1.0	
Hold-down tape width	W ₀	6.0	minimum	
Hole position	W ₁	9.0	±0.75	
Hold down tape position	W ₂	3.0	maximum	
Height of component from tape center	H	20.0	±1.0	
Height of component from tape center - Kink	H ₀	16.0	±0.5	
Lead wire protrusion	f	2.0	maximum	
Feed hole diameter	D ₀	4.0	±0.3	
Total tape thickness	t	0.7	±0.2	Ground paper: 0.5 ± 0.1mm
Length of snapped lead	L	11.0	maximum	
Coating rundown on leads	C	2.0	maximum	

These radial taped ceramic disc capacitors are designed especially for automatic insertion.

The available types for radial taped disc are diameters 11.0mm and under.

Anchor with a stapler when the tape is cut or completed. It is accepted that up to three parts may become detached from the tape.

SMD TAPING SPECIFICATIONS

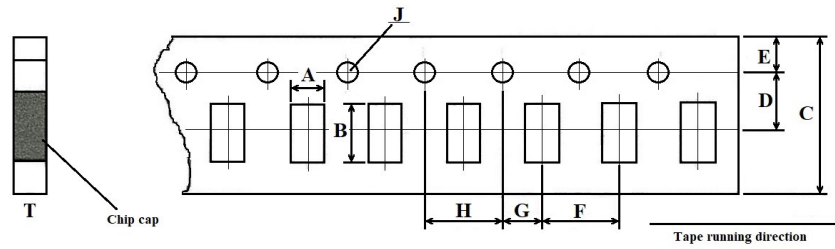

Type	A	B	C	D	E	F	G	H	J	T
01005	0.24 ± 0.20	0.45 ± 0.20	8.00 ± 0.10	3.50 ± 0.05	1.75 ± 0.10	2.00 ± 0.05	2.00 ± 0.10	4.00 ± 0.10	1.50 + 0.1-0	0.30 Below
0201	0.37 ± 0.10	0.67 ± 0.10	8.00 ± 0.10	3.50 ± 0.05	1.75 ± 0.10	2.00 ± 0.10	2.00 ± 0.10	4.00 ± 0.10	1.50 + 0.1-0	0.80 Below
0402	0.65 ± 0.1	1.15 ± 0.10	8.00 ± 0.10	3.50 ± 0.05	1.75 ± 0.10	2.00 ± 0.10	2.00 ± 0.10	4.00 ± 0.10	1.50 + 0.1-0	0.80 Below
0603	1.1 ± 0.10	1.90 ± 0.10	8.00 ± 0.10	3.50 ± 0.05	1.75 ± 0.10	4.00 ± 0.10	2.00 ± 0.10	4.00 ± 0.10	1.50 + 0.1-0	1.10 max
0805	1.45 ± 0.15	2.30 ± 0.15	8.00 ± 0.15	3.50 ± 0.05	1.75 ± 0.10	4.00 ± 0.10	2.00 ± 0.10	4.00 ± 0.10	1.50 + 0.1-0	1.10 max
1206	1.80 ± 0.20	3.40 ± 0.20	8.00 ± 0.20	3.50 ± 0.05	1.75 ± 0.10	4.00 ± 0.10	2.00 ± 0.10	4.00 ± 0.10	1.50 + 0.1-0	1.10 max
1210	2.70 ± 0.10	3.42 ± 0.10	8.00 ± 0.10	3.50 ± 0.05	1.75 ± 0.10	4.00 ± 0.10	2.00 ± 0.05	4.00 ± 0.10	1.55 + 0.1-0	3.20 max
1808	2.20 ± 0.10	4.95 ± 0.10	12.0 ± 0.10	5.50 ± 0.05	1.75 ± 0.10	4.00 ± 0.10	2.00 ± 0.05	4.00 ± 0.10	1.50 + 0.1-0	3.00 max
1812	3.66 ± 0.10	4.95 ± 0.10	12.0 ± 0.10	5.50 ± 0.05	1.75 ± 0.10	8.00 ± 0.10	2.00 ± 0.05	4.00 ± 0.10	1.55 + 0.1-0	4.00 max
2220	6.20 ± 0.10	6.70 ± 0.10	12.0 ± 0.10	5.50 ± 0.05	1.75 ± 0.10	8.00 ± 0.10	2.00 ± 0.05	4.00 ± 0.10	1.55 + 0.1-0	2.40 ± 0.10

01005 ~ 1206 - Paper Tape
 1210 ~ 2220 - Plastic Tape

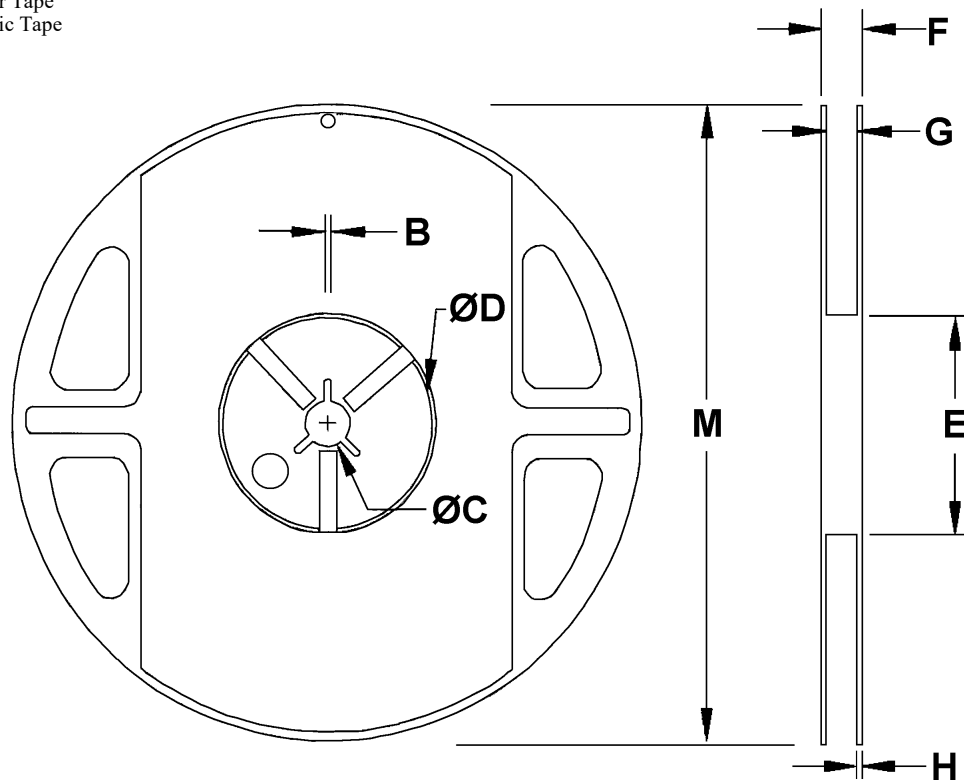

B	C	D	E	F	G	H	M
3.0	13.0 ± 0.5	21.0 ± 0.8	50 or more	12 max	10.0 ± 1.5	0.8 ± 0.15	178 ± 2 (7")

LEAD STYLES

When ordering Sanyo-CAP disc ceramic capacitors, the default lead style is as illustration "A" below. When a lead style other than the default lead type is required, specify the letter code below at the end of the Sanyo-CAP part number.

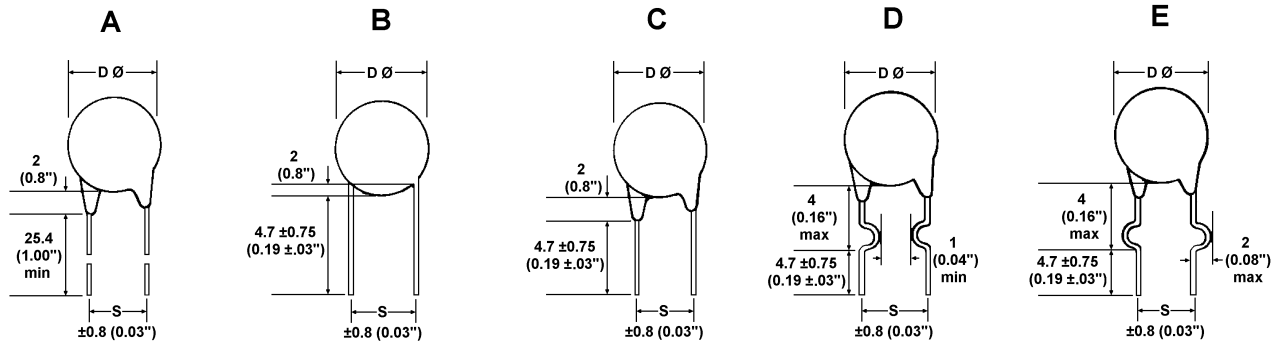

UNIT : mm

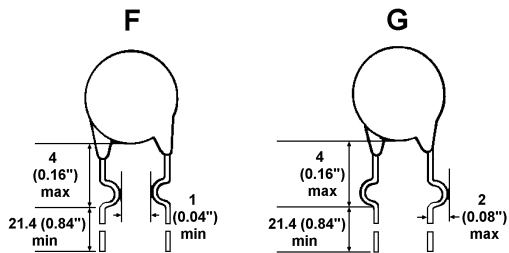

- A Coverage Leads - Standard Lead Configuration. Long Straight Leads.
- B Exposed Disc and Cut Leads
- C Coverage and Cut Leads
- D Inside Kink and Cut Leads
- E Outside Kink and Cut Leads
- F Inside Kink and Long Leads
- G Outside Kink and Long Leads
- X For other specifications not illustrated, contact S-P International for information.

NOTE: Not all lead configurations are available on all series types. Contact S-P International for more information

Available Lead Spacing

2.5mm (0.1") 5mm (0.2") 6.35mm (0.25") 7.5mm (0.3") 9.5mm (0.37")

Default lead spacing is dependant on diameter of part. Custom lead spacing is available for most body diameters. Default lead spacing for Tape & Reel or Tape-Ammo is 5mm (0.2").

TYPICAL CHARACTERISTICS

T.C. CHART

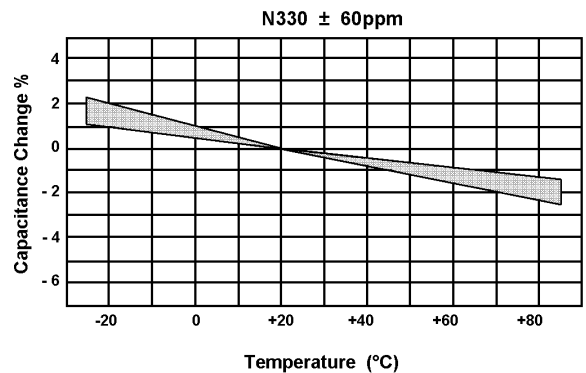
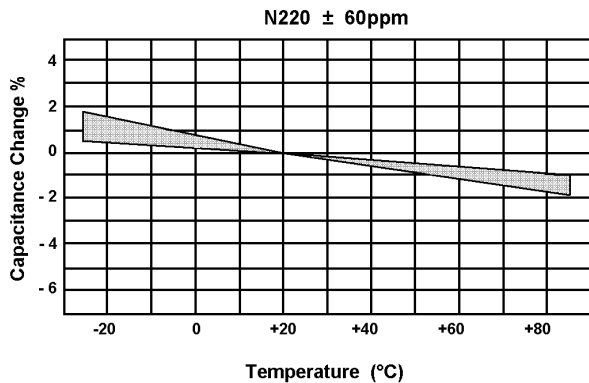
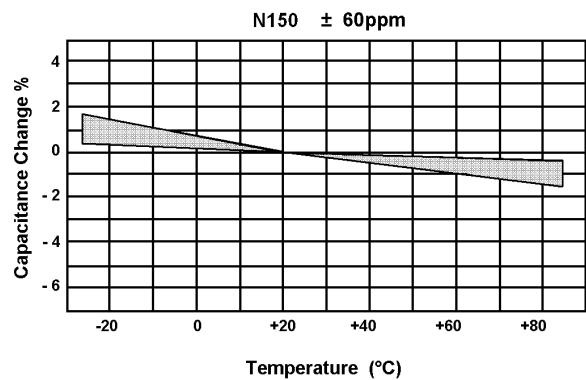
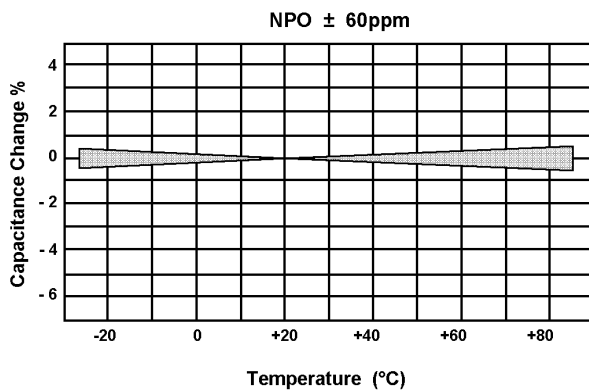
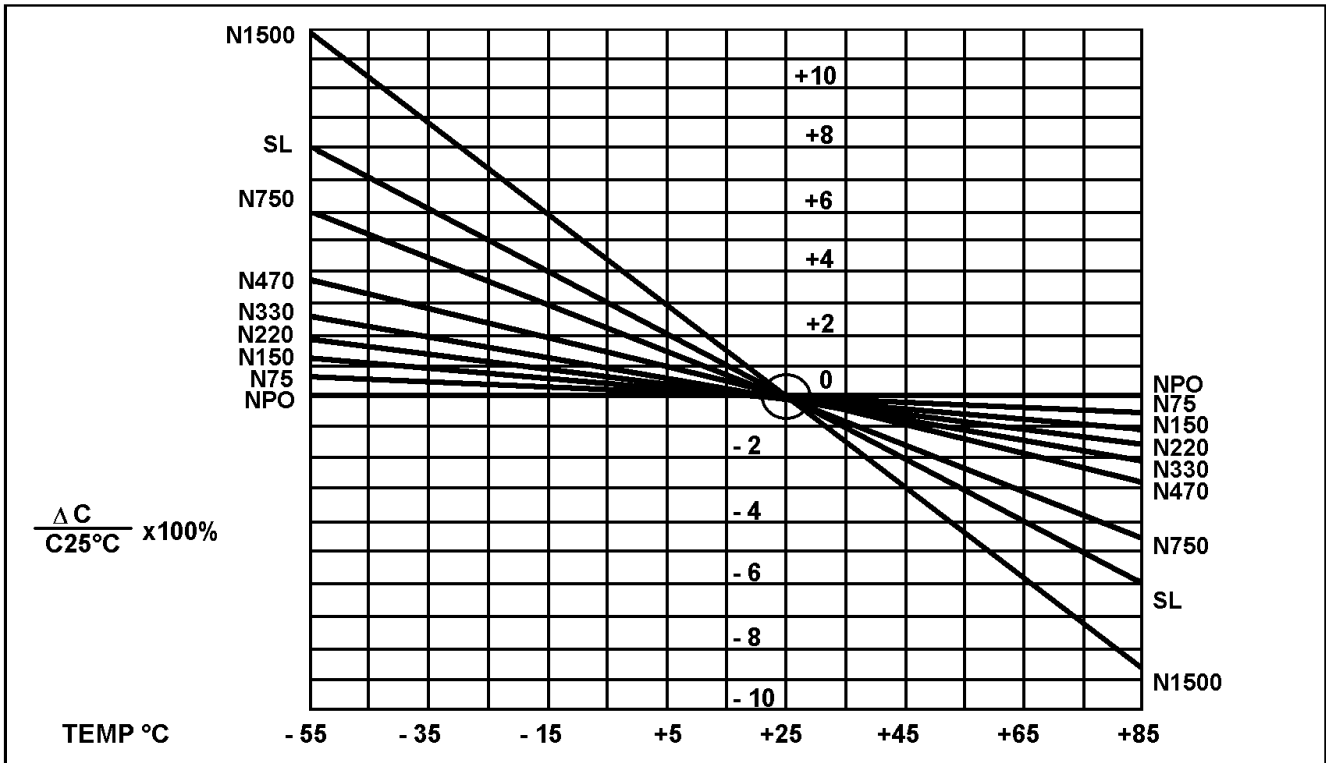

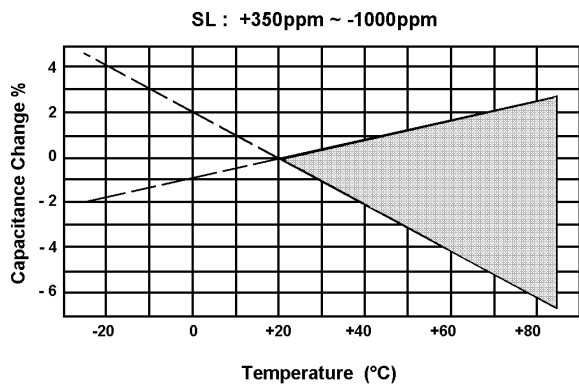
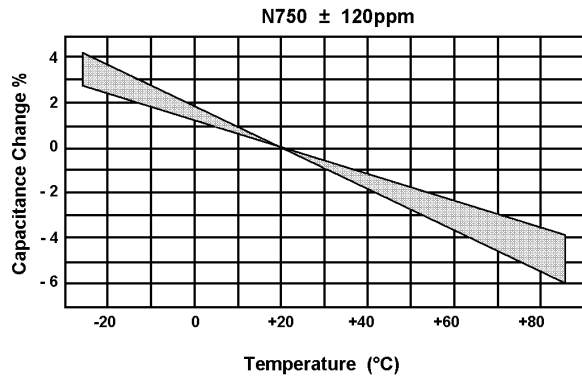
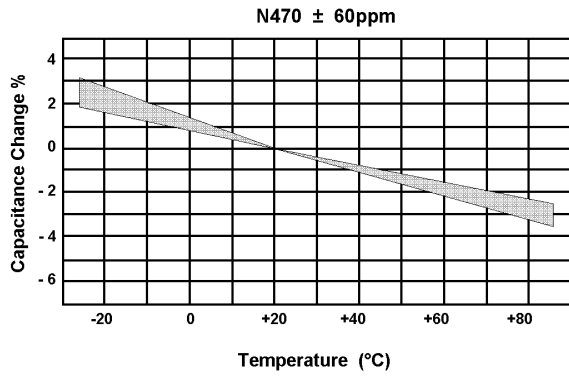

HI-K TYPE

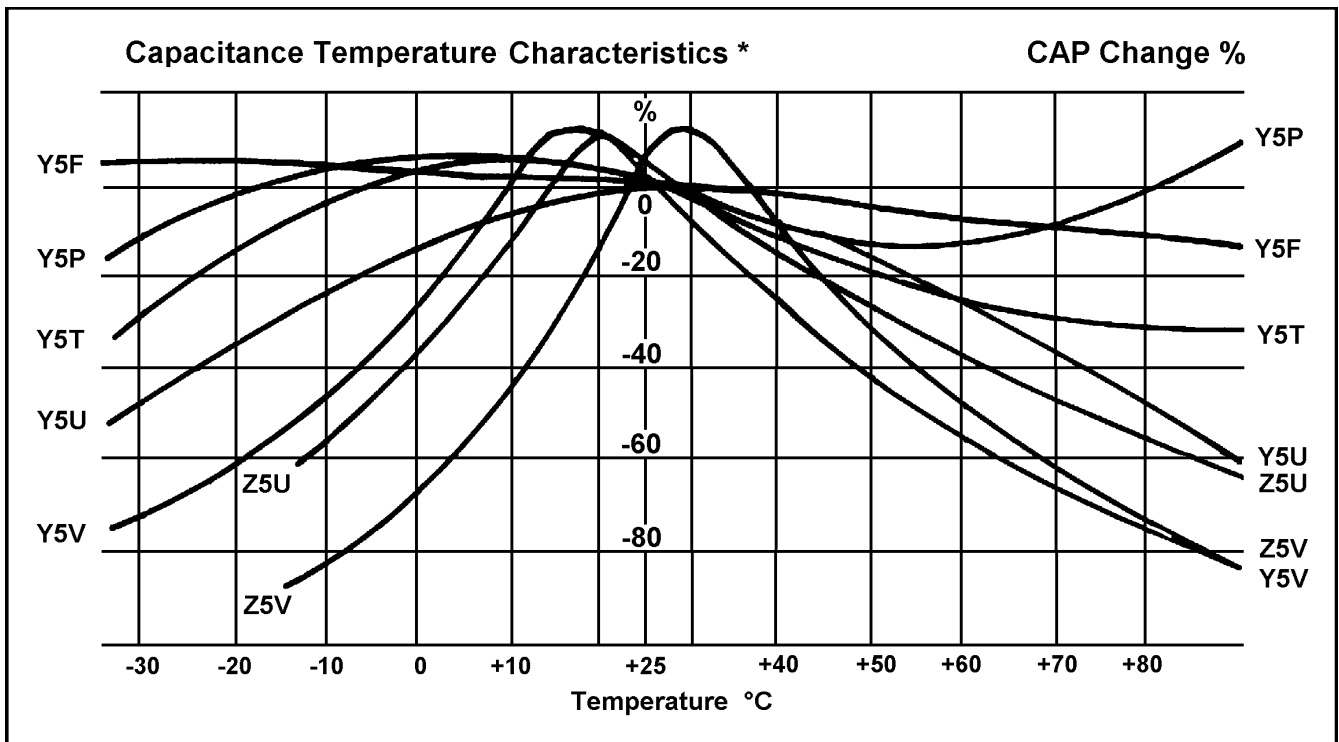

HI-K TYPE continued

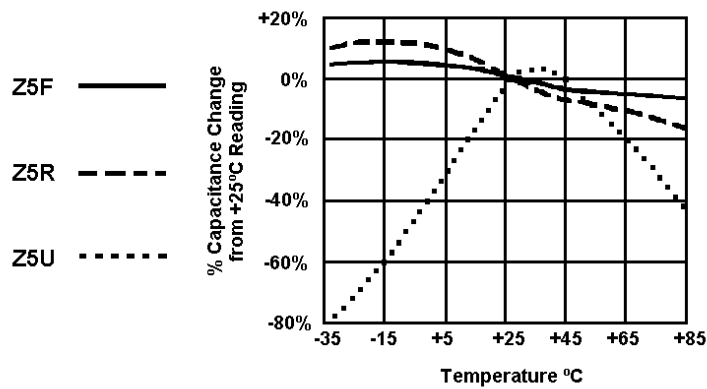
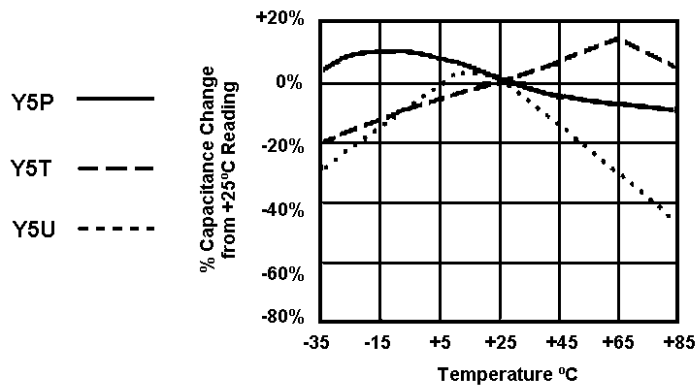
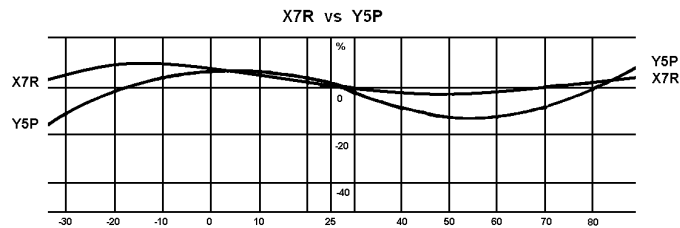

GENERAL NOTES

T.C. TYPE

NPO	0± (COG=30, COH=60, COJ=120, COK=250) ppm/°C max. capacitance change from +25°C reading over temperature range of 25°C to +85°C
N75	±60 ppm/°C max. capacitance change from +25°C reading over temp. range of -25°C to +85°C
N150	±60 ppm/°C max. capacitance change from +25°C reading over temp. range of -25°C to +85°C
N220	±60 ppm/°C max. capacitance change from +25°C reading over temp. range of -25°C to +85°C
N330	±60 ppm/°C max. capacitance change from +25°C reading over temp. range of -25°C to +85°C
N470	±60 ppm/°C max. capacitance change from +25°C reading over temp. range of -25°C to +85°C
N750	±120 ppm/°C max. capacitance change from +25°C reading over temp. range of -25°C to +85°C
N1500	±250 ppm/°C max. capacitance change from +25°C reading over temp. range of -25°C to +85°C
N3300	±2500 ppm/°C max. capacitance change from +25°C reading over temp. range of -25°C to +85°C
SL	+350 -1000 ppm/°C max. capacitance change from +25°C reading over temp. range of -25°C to +85°C

Hi-K TYPE

X5F	±7.5% max. capacitance change from +25°C reading over temp. range of -55°C to +85°C
X7R	±15% max. capacitance change from +25°C reading over temp. range of -55°C to +125°C
Y5F	±7.5% max. capacitance change from +25°C reading over temp. range of -30°C to +85°C
Y5P	±10% max. capacitance change from +25°C reading over temp. range of -30°C to +85°C
Y5R	±15% max. capacitance change from +25°C reading over temp. range of -30°C to +85°C
Y5T	+22% -33% max. capacitance change from +25°C reading over temp. range of -30°C to +85°C
Y5U	+22% -56% max. capacitance change from +25°C reading over temp. range of -30°C to +85°C
Y5V	+22% -82% max. capacitance change from +25°C reading over temp. range of -30°C to +85°C
Z5F	±7.5% max. capacitance change from +25°C reading over temp. range +10°C to +85°C
Z5P	±10% max. capacitance change from +25°C reading over temp. range of +10°C to +85°C
Z5R	±15% max. capacitance change from +25°C reading over temp. range of +10°C to +85°C
Z5U	+22% -56% max. capacitance change from +25°C reading over temp. range of +10°C to +85°C
Z5V	+22% -82% max. capacitance change from +25°C reading over temp. range of +10°C to +85°C

EIA TEMPERATURE CHARACTERISTIC CHART

The above Hi-K Type codes are set by EIA standards. The base breakdown for these codes is noted below.

1st Digit	X = -55°C		Y = -30°C		Z = +10°C	
2nd Digit	4 = +65°C	5 = +85°C	6 = +105°C	7 = +125°C	8 = +150°C	
3rd Digit	A = 1.0%	B = 1.5%	C = 2.2%	D = 3.3%	E = 4.7%	F = 7.5%
	P = 10%	R = 15%	S = 22%	T = +22% - 33%	U = +22% - 56%	V = +22% - 82%

Ceramic capacitors, depending on manufacture, may have an alternate designation for the same base EIA Specification. We have attempted to list some of these alternate names below for your reference.

Material	NPO	N75	N150	N220	N330	N470	N750	N1000	N1500	N3300	SL
Alternate	COG, COH, CH, COK COJ	LH	PH	RH	S2L, SH	TH	U2J, UJ		P3K	S3N	GP

Material	X7R	Y5P	Y5R	Y5T	Y5U	Y5V	Z5F	Z5P	Z5R	Z5U	Z5V
Alternate		B	RY, SR		E	FY, SF				E	F

S-P International makes no claims as to the absolute accuracy of this chart. This chart should be used as a guide only. Due to the nature of the product, care must be taken to ensure the specific capacitor specifications match. S-P International cannot take responsibility for incorrectly crossed components.

LEAD FREE (Pb)

Lead Free parts are now standard for all products included in this catalogue unless otherwise noted. All parts are RoHS and REACH compliant. Please contact S-P International or your local distributor for availability.

SPECIAL ORDERS

While a wide variety of ceramic capacitor products are listed in this catalogue, not all products are standard stock items with S-P International or it's distributors. Special order items may be subject to a factory minimum order and are NCNR (Not Subject to Cancellation and/or Return) once ordered. Contact S-P International or your local distributor for more details.

ERRORS & OMISSIONS

Every attempt has been made to ensure the information in this catalogue is accurate and up-to-date. Please report any errors or omissions directly to S-P International.

CAPACITANCE VALUE DESIGNATIONS

Capacitor values are always expressed in terms of Farads, or a portion of a Farad, such as: picofarad, nanofarad or microfarad. How a capacitor value is expressed, is in many cases, dependent on who is publishing the specification.

1 . 000 , 000 , 000 , 000
F μ n p

Typically, a capacitance value is expressed in either microfarads or picofarads. Example: 10,000pF. This capacitor value however, can be expressed in three different ways. 0.01 microfarads, or 10 nanofarads, or 10,000 picofarads.

0.010 microfarad (μF)
10 nanofarad (nF)
10,000 picofarad (pF)

In some old literature, you may also see the designation μμF. This is the same as pF.

REFLOW & WAVE SOLDER TEMPERATURE CHART for SMD

Reflow Soldering

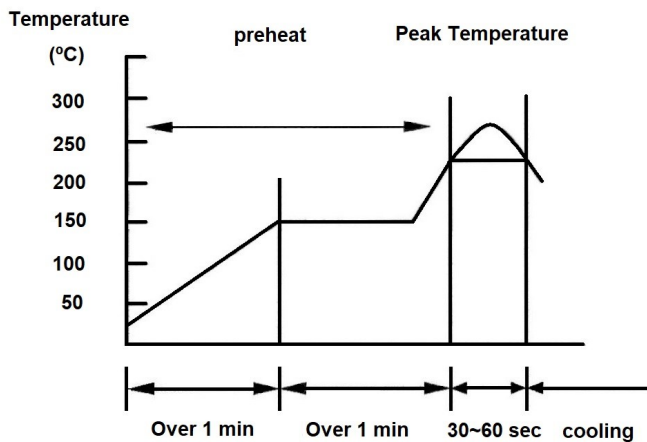

	Pb-Sn Soldering	Lead-free Soldering
Peak Temperature	230°C ~ 250°C	240°C ~ 260°C

Wave Soldering

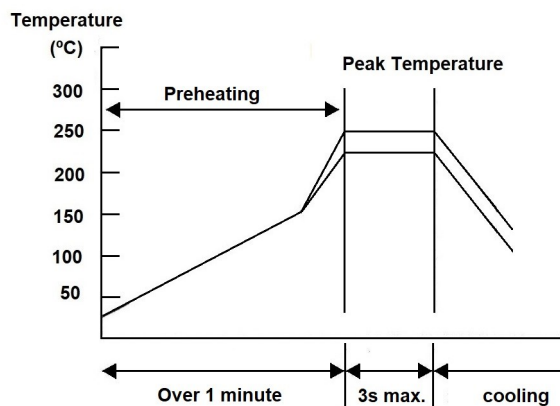

	Pb-Sn Soldering	Lead-free Soldering
Peak Temperature	230°C ~ 260°C	240°C ~ 270°C

While in preheating, please keep the temperature difference between soldering temperature and surface temperature of chips as: $T \leq 150^\circ\text{C}$



Head Office and Warehouse

100 - 5118 North Fraser Way
Burnaby, British Columbia, V5J 0H1
Phone - 604-324-4811
Fax - 604-324-3184
E-Mail - info@s-pintl.com
Web - www.s-pintl.com

Eastern Sales Office

200 - 550 Alden Road
Markham, Ontario, L3R 6A8
Phone - 905-475-5305
Fax - 905-475-5462

Follow us on: [!\[\]\(5a132f13505a6571904d622757b7a8f0_img.jpg\)](#) [!\[\]\(0f17417dd77a61b2fdbff69a33adf9f2_img.jpg\)](#)