

金属屏蔽型电缆接头

Metal Cable Gland-EMC-W Type

M / PG / G / NPT



材质: 镀镍黄铜	Material: Nickel-plated brass
夹紧爪: 尼龙塑料 PA66, UL94-V2	Claw: PA66 (Nylon), UL94-V2
密封件: 三元乙丙、硅橡胶等	Hermetic seal: EPDM, Silicone rubber
防水圈: 三元乙丙、硅橡胶等	O-Ring: EPDM, Silicone rubber
防水等级: IP68-10 巴压力	Protection degree: IP68-10 bar
工作温度: 静态: -40°C到 100°C, 短时间达 120°C	Temperature: Static state: -40 °C to 100 °C ,Short time to 120 °C ;Dynamic state: -20 °C to 80°C ,Short time to 100°C
动态: -20°C到 80°C, 短时间达 100°C	

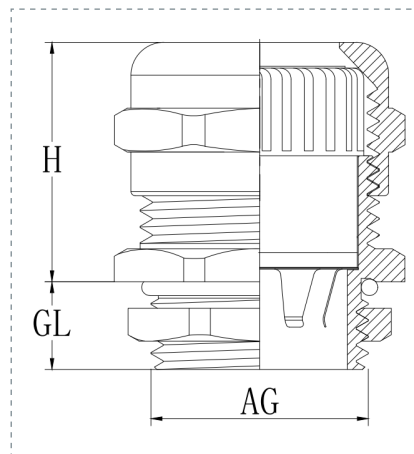

规格参数 单位: mm

规格 Item	适用范围 Φ Range	螺纹长度 GL Thread Length	接合长度 H Joint Length	扳手径 Spanner size	产品编号 Code
M12×1.5	3-6.5	6.5	19	14	EMC.M12-W
M16×1.5	4-8	8	20	18	EMC.M16-W
	5-10	8	21	20/18	EMC.M16-10-W
M18×1.5	5-10	8	21	20	EMC.M18-W
M20×1.5	6-12	8	22	22	EMC.M20-W
	10-14	8	23	24/22	EMC.M20-14-W
M22×1.5	10-14	8	23	24	EMC.M22-W
	10-14	9	25	24/27	EMC.M25-14-W
M25×1.5	12-16	9	27	27	EMC.M25-16-W
	13-18	9	27	30/27	EMC.M25-18-W
M32×1.5	15-22	10	29	35	EMC.M32-W
	18-25	10	31	40/35	EMC.M32-25-W
M40×1.5	18-25	11	31	40/45	EMC.M40-25-W
	22-30	11	35	45	EMC.M40-30-W
	25-33	11	37	50/45	EMC.M40-33-W
M50×1.5	32-38	13	37	57/55	EMC.M50-W
	37-44	14	38	64/68	EMC.M63-W
M63×1.5	42-52	14	38	78/68	EMC.M63-52-W
	42-52	16	42	78	EMC.M72-W
M80×2	55-62	18	45	88	EMC.M80-W
M88×2	65-70	18	45	94	EMC.M88-W
M100×2	78-84	20	53	110	EMC.M100-W

可选择 PG / G / NPT 螺纹
PG/G/NPT threads are available

